



MOBICLINIC

CATÁLOGO GENERAL

GENERAL CATALOGUE | CATALOGUE GÉNÉRAL

2019

MOBILIARIO CLÍNICO
CLINICAL FURNITURE
MOBILIER CLINIQUE

www.mobiclinic.com
www.medtrolley.com



FABRICACIÓN DE ALTA CALIDAD.
HIGH QUALITY MANUFACTURING.
FABRICATION DE HAUTE QUALITÉ



EMBAJADOR DE MARCA MOBICLINIC
ALTA CALIDAD DE FABRICACIÓN ESPAÑOLA, COMO LA ALTA CALIDAD DEL MOTOCICLISMO ESPAÑOL MOTO GP.

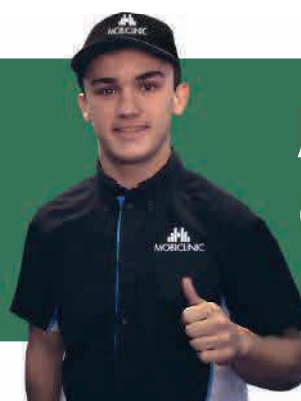

ARÓN CANET
(PILOTO DEL MUNDIAL MOTO GP MOTO 3)



MOBICLINIC S.L., empresa española líder en la fabricación de mobiliario clínico y equipamiento hospitalario desde 1.986, presenta su nuevo catálogo. En este nuevo catálogo, atendiendo a las demandas del mercado, hemos incluido nuevos productos que amplía aún más nuestra extensa oferta.

MOBICLINIC, S.L., Spanish company leader in clinical furniture and medical equipment since 1986, presents its new brochure. In order to satisfy the needs of the market, we have included new products which extend our variety range.

MOBICLINIC, S.L., première entreprise espagnole pour la fabrication de mobilier clinique et d'équipement des hôpitaux depuis 1986, vous présente son nouveaux catalogue. Dans ce nouveau catalogue, suivant les demandes du marché, nous avons inclus de nouveaux produits qui on enrichi notre ample offre.



Atención telefónica personalizada para cualquier consulta en el 955 631 230.

Personalized phone consultation on 0034 955 631 230.
Téléphone personnalisé pour consultation 0034 955 631 230.



Disponemos de un equipo de profesionales especializado en la fabricación de mobiliario a medida.

We have a professionals team specialized in manufacturing customized furniture.
Nous avons une équipe de professionnels spécialisés dans la fabrication de meubles sur mesure.



Los artículos son constantemente actualizados en nuestra web, donde podrán descargar sus características técnicas y fotografías.

The articles are constantly updated on our website, where you can download their technical specifications and photographs.
Les articles sont constamment mis à jour sur notre site web, vous pouvez télécharger leurs spécifications techniques et aux photographies.



www.mobiclinic.com

ÍNDICE INDEX

Carros
Trolleys
Chariots

6



**Carros varios
USOS**
Trolleys
Chariots

38



Pediatría
Pediatric
Pédiatrique

54



Mesas
Tables

59



Camillas
Examination tables
Tables d'examen

73



Sillones
Armchair
Fauteuil

82



Taburetes
Stools
Tabourets

95



Vitrinas
Cabinets
Vitrines

101



Auxiliar
Auxiliary
Auxiliar

106



Almacenaje
Storage
Stockage

133

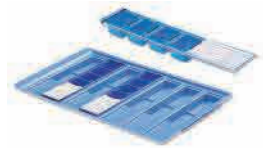

Muebles inox
Stainless steel
equipment
Équipement inox

142



Colectividad
Collectivity
Collectivité

157



**Ayudas técnicas
y material médico**
Technical aids and
medical equipment
Aides techniques et
équipement médical

164





carros

trolleys

chariots

carros

trolleys
chariots

medtrolley

serie / series/ série 800 / 900

serie / series/ série 1000

serie / series/ série 2000 MINI

serie / series/ série 2000

VANGUARDIA CLÍNICA

AVANT-GARDE CLINICAL

AVANT-GARDE CLINIQUE



Carro fabricado sobre base rígida en polietileno con protección anti-golpes. Estructura principal de perfil extrusionado en aluminio de gran resistencia. Laterales contruidos en acero inoxidable. Frontes de cajón en polietileno, disponibles en 3 alturas y en varios colores según las dimensiones. Montados sobre guías metálicas con auto-cierre y extracción total.

Rigid anti shock base, made of moulded polythene. Main structure built in aluminium of great resistance. Sides manufactured in stainless steel. Fronts of drawers made of blown polythene, available in 3 heights and several colours (it depends on measurements).

Base rigide fabriqué de polyéthylène, avec protection contre les chocs. Structure en aluminium extrudé de une grande résistance. Côtés en acier inoxydable. Fronts de tiroirs de polyéthylène, disponible en 3 hauteurs, différentes couleurs selon les dimensions.

Consulte el CATÁLOGO de MEDTROLLEY para más información.

Consult the MEDTROLLEY CATALOGUE for more information.

Consultez le CATALOGUE DE MEDTROLLEY pour en plus d'information.



FABRICADO
EN ACERO INOX.
AISI
304 18/10



MEDTROLLEY



Diseño galardonado con la máxima categoría BIANUARIO



Top Award desing BIANUARIO
Premier Prix design BIANUARIO

Bandeja superior de inyección con divisiones y empujadores ergonómicos para un fácil manejo del carro. Especialmente diseñada para contener:

Caja de guantes, bote de desechos e instrumental.

Injected polypropylene upper tray with ergonomic push-handles. Specially designed to contain: glove box, waste disposal container and set of instruments.

Plateau supérieur en polypropylène injecté avec les divisions, et les pousseurs ergonomi que pour une manipulation aisée de le chariot.

CAJONES / DRAWERS / TIROIRS

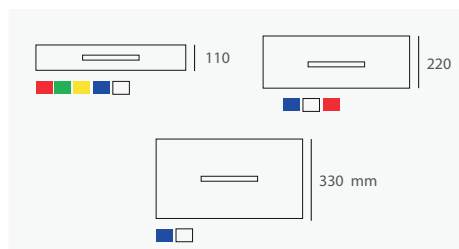

Múltiples configuraciones posibles.

Several configurations and accessories are available.

Plusieurs configurations et accessoires sont disponibles.

Incluye 2 bandejas laterales en acero inoxidable, 2 cajones laterales transparentes abatibles, una papelera con tapa y soporte para botella de oxígeno. Ruedas paralelas Ø100mm, 2 con freno.

Includes two lateral stainless steel trays, 2 lateral tilted transparent drawers, waste-bin with lid and oxygen bottle holder on one side. Parallel wheels Ø100mm, 2 with brakes.

Le chariot inclut aussi: deux plateaux en acier inoxydable, 2 porte-documents transparents basculent, une poubelle avec couvercle et un support bouteille d'oxygène. Roues Ø100mm parallèle, 2 avec frein.

Ruedas de colores con opción de serigrafía.

Colored wheel with serygraphy option.

Roues de couleur avec option de sérigraphie.

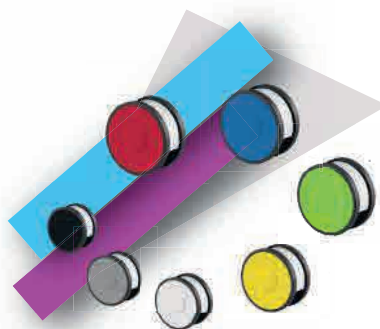

carros

trolleys
chariots

medtrolley
serie / series/ série 800 / 900
serie / series/ série 1000
serie / series/ série 2000 MINI
serie / series/ série 2000

Medtrolley BÁSICO

Además de las características que son estándar en todos los Medtrolley tiene 3 cajones de diferentes alturas (1x110 mm +1x220 mm +1x330 mm).

🇬🇧 Medtrolley BASIC

Apart from the features that are standard in every Medtrolley, this model has 3 drawers of different heights (1x110 mm +1x220 mm +1x330mm).

🇫🇷 Medtrolley BASIQUE

Outre les caractéristiques qui sont la norme dans toutes les Medtrolley, ce modèle dispose de 3 tiroirs de hauteurs différentes (1x110 mm +1x220mm+1x330 mm).



Jq760



Jq760



920x725x910 mm



52 kg

Medtrolley CURAS

Además de las características que son estándar en todos los Medtrolley, este modelo cuenta con 3 cajones pequeños (110 mm H) con divisiones interiores y un cajón grande (330 mm H) en la parte inferior.

🇬🇧 Medtrolley DRESSING

Apart from the features that are standard in every Medtrolley, this model has 3 small drawers (110 mm H) with partitions and one big drawer (330 mm H) in lower part.

🇫🇷 Medtrolley SOINS

Outre les caractéristiques qui sont la norme dans toutes les Medtrolley, ce modèle dispose de 3 petits tiroirs (110 mm H) avec separations et un grand tiroir (330 mm H) dans la partie inférieure.



Jq760-1



JQ760-1



920x725x910 mm



58 kg

carros

trolleys
chariots

medtrolley
serie / series/ série 800 / 900
serie / series/ série 1000
serie / series/ série 2000 MINI
serie / series/ série 2000

Medtrolley ANESTESIA

Además de las características que son estándar en todos los Medtrolley, este modelo cuenta con 3 cajones de diferentes alturas (1x110 mm +1x220 mm +1x330 mm), soporte superior de aluminio con rail de acero inoxidable para colgar aparataje, 2 filas de cajitas basculantes transparentes de 5 y 6 compartimentos y portasueros de acero inoxidable.

🇬🇧 Medtrolley ANESTHESIA

Apart from the features that are standard in every Medtrolley, this model has 3 drawers of different heights (1x110 mm +1x220 mm +1x330 mm). Upper part with aluminum support with rail to hang apparatus, 2 rows of tilting boxes with 5 and 6 compartments. IV pole in stainless steel.

🇫🇷 Medtrolley ANESTHÉSIE

Outre les caractéristiques qui sont la norme dans toutes les Medtrolley, ce modèle dispose de 3 tiroirs de hauteurs différentes (1x110 mm +1x220 mm +1x330 mm). Partie supérieure avec support en aluminium avec rail pour accrocher appareil, 2 rangées de boîtes basculantes à 5 et 6 compartiments. Tige porte-sérum en acier inoxydable.

Jq760-2



JQ760-2



900x725x1570 mm



72 kg

Medtrolley PARADA 3 cajones

Además de las características que son estándar en todos los Medtrolley, este modelo cuenta con 3 cajones de diferentes alturas (1x110 mm +1x220 mm +1x330 mm). Cajón superior con separadores. Accesorios incluidos: tabla de parada, portasueros regulable en altura con 2 ganchos en acero inoxidable, base de conexión eléctrica y soporte para desfibrilador. Bloqueador mediante precinto.

🇬🇧 Medtrolley EMERGENCY 3 drawers

Apart from the features that are standard in every Medtrolley, this model has 3 drawers of different heights (1x110 mm +1x220 mm +1x330 mm). Upper drawer with dividers. Accessories: cardiac massage board, serum holder in stainless steel with 2 hooks, defibrillator support and electric socket. Blocking system by seals.

🇫🇷 Medtrolley URGENCE 3 tiroirs

Outre les caractéristiques qui sont la norme dans toutes les Medtrolley, ce modèle dispose de 3 tiroirs de hauteurs différentes (1x110 mm +1x220 mm +1x330 mm). Tiroir supérieur avec séparateurs. Accessoires: planche de massage cardiaque, tige-porte sérum en acier inoxydable avec 2 crochets et hauteur ajustable, plateau pour défibrillateur, et multiprise. Fermeture pour scelle.

Jq760-3



JQ760-3



900x725x920 mm



58 kg

carros

trolleys
chariots

medtrolley
serie / series/ série 800 / 900
serie / series/ série 1000
serie / series/ série 2000 MINI
serie / series/ série 2000

Medtrolley PARADA 5 cajones

Además de las características que son estándar en todos los Medtrolley, este modelo cuenta con 4 cajones pequeños (110 mm H) y un cajón mediano (220 mm H) en la parte inferior. Cajón superior con separadores. Accesorios incluidos: tabla de parada, portasueros regulable en altura con 2 ganchos en acero inoxidable, base de conexión eléctrica y soporte para desfibrilador. Cajones de colores. Bloqueador mediante precinto.

🇬🇧 Medtrolley EMERGENCY 5 drawers

Apart from the features that are standard in every Medtrolley, this model has 4 small drawers (110 mm H) and one medium drawer (220 mm H) in lower part. Upper drawer with dividers. Accessories: cardiac massage board, serum holder in stainless steel with 2 hooks, defibrillator support and electric socket. Colored drawers. Blocking system by seals.

🇫🇷 Medtrolley URGENCE 5 tiroirs

Outre les caractéristiques qui sont la norme dans toutes les Medtrolley, ce modèle dispose de 4 petits tiroirs (110 mm H) et un tiroir (220 mm H) dans la partie inférieure. Tiroir supérieur avec séparateurs. Accessoires: planche de massage cardiaque, tige-porte sérum en acier inoxydable avec 2 crochets et hauteur ajustable, plateau pour défibrillateur, et multiprise. Tiroirs de couleurs. Fermeture pour scelle.



Jq760-3-5C



910x725x910 mm



62 kg

Medtrolley MEDICACIÓN

Además de las características que son estándar en todos los Medtrolley, este modelo cuenta con 4 cajones pequeños (110 mm H) con separadores y un cajón mediano (220 mm H) en la parte inferior. Soporte superior de aluminio con bandeja de acero inoxidable y 2 filas de cajitas basculantes transparentes de 5 y 6 compartimentos.

🇬🇧 Medtrolley MEDICATION

Apart from the features that are standard in every Medtrolley, this model has 4 small drawers (110 mm H) with dividers and one medium drawer (220 mm H) in lower part. Upper part with aluminum support with one stainless steel tray and 2 rows of tilting boxes with 5 and 6 compartments.

🇫🇷 Medtrolley MEDICAMENTS

Outre les caractéristiques qui sont la norme dans toutes les Medtrolley, ce modèle dispose de 4 petits tiroirs (110 mm H) avec séparations et un tiroir (220 mm H) dans la partie inférieure. Partie supérieure avec support en aluminium avec plateau en acier inoxydable et 2 rangées de boîtes basculantes à 5 et 6 compartiments.

Jq760-4



Jq760-4



900x725x1570 mm



72 kg

carros

trolleys
chariots

medtrolley
serie / series/ série 800 / 900
serie / series/ série 1000
serie / series/ série 2000 MINI
serie / series/ série 2000

Medtrolley PEDIÁTRICO

Jq760-5

Además de las características que son estándar en todos los Medtrolley, este modelo cuenta con 3 cajones de 220 mm H, con cestas de acero inox en su interior. La bandeja superior con barandilla en 3 lados, y colchón lavable (600x540x50 mm).

🇬🇧 Medtrolley PEDIATRIC

Apart from the features that are standard in every Medtrolley, this model has 3 drawers of 220 mm H, with stainless steel baskets in its interior. Worktop with stainless steel railing on three sides and washable mattress (600x540x50 mm).

🇫🇷 Medtrolley PÉDIATRIQUE

Outre les caractéristiques qui sont la norme dans toutes les Medtrolley, ce modèle dispose de 3 tiroirs de 220 mm H, avec paniers d'acier inoxydable dans son intérieur. Plan de travail avec galerie dans 3 côtés en acier inoxydable et matelas lavable (600x540x50 mm).



REF



KG

JQ760-5

900x725x1040 mm

54 kg

Medtrolley DISTRIBUCIÓN

Jq760-6

Además de las características que son estándar en todos los Medtrolley, este modelo cuenta con 8 cajones de 110mm H con separadores. Incluye 1 bandeja adicional de acero inoxidable con barandilla.

🇬🇧 Medtrolley DISTRIBUTION

Apart from the features that are standard in every Medtrolley, this model has 8 drawers of 110mm H, with dividers. It includes 1 additional lateral stainless steel trays with railing.

🇫🇷 Medtrolley DISTRIBUTION

Outre les caractéristiques qui sont la norme dans toutes les Medtrolley, ce modèle dispose de 8 tiroirs de 110mm H, avec séparations. Il inclut 1 plateau latéraux additionnelle d'acier inoxydable avec galerie.



REF



KG

JQ760-6

900x725x1118 mm

85 kg

carros

trolleys
chariots

medtrolley
serie / series/ série 800 / 900
serie / series/ série 1000
serie / series/ série 2000 MINI
serie / series/ série 2000

Medtrolley PORTA-HISTORIAS

Jq760-7

Este modelo cuenta con 1 cajón de polietileno 110 mm alto, 2 cajones de polietileno 330 mm alto, para colgar carpetas, 2 cajones basculantes laterales transparentes (uno a cada lado) y cierre centralizado.

Medtrolley PORTA HISTORY

This model has 1 small drawers 110 mm high, 2 drawers 330 mm high for hanging folders , 2 Tilted transparent draws (one on each side) and central locking.

Medtrolley PORTA HISTOIRE

Ce modèle dispose de 1 petits tiroirs de 110 mm modes, 2 tiroirs 330 mm de pour dossiers suspendus , 2 porte-documents transparent basculent (un de chaque côté) et le verrouillage centralisé.



REF



KG

JQ760-7

900x725x1025 mm

58 kg

Configure su Medtrolley [a su gusto](#)

ESTRUCTURA / STRUCTURE

Incluye la estructura completa base, superficie de trabajo, soporte de botella de oxígeno y ruedas paralelas de 100 mm (2 con freno).

Trolley structure includes work surface , oxygen bottle holder, and parallel wheels of 100 mm (2 with brakes).

Il inclut la structure basse, surface de travail, support pour bouteille d'oxygen et roulettes parallels de 100 mm.

REF



KG

Jq760-est

900x725x910 mm

36 kg



ACCESORIOS

ACCESSORIES

ACCESSOIRES

ACCESORIOS PARA MEDTROLLEYS / ACCESSORIES FOR MEDTROLLEYS / ACCESSOIRES POUR MEDTROLLEY



Colchón de espuma compacta.

Compact foam mattress.
Matelas en mousse compacte.

REF MED007-A



Bandeja para soporte perfil.

Tray for aluminium support.
Plateau pour support d'aluminium.

REF MED0026



Rail soporte aparatos.

Railing support.
Rail support d'appareils.

REF MED0018



Estructura perfil de aluminio con dispensadores basculantes y bandeja.

Aluminium support with tilted dispensers and tray.

Profile d'aluminium avec dispensateurs et plateau.

REF MED0016-01



Estructura tubular con 8 cestas.

Tubular structure with 8 baskets.

Structure tubulaire avec 8 paniers

REF MED0031-A



Bandeja suspendida en acero inoxidable.

Hanged tray in stainless steel.
Plateau en acier inoxydable

REF MED0011-A



Foco halógeno, baja temperatura.

Halogen lamp, low temperature

REF MED0044



Cierre centralizado.

Central locking system.
Système de fermeture centralisé.

REF MED0015

ACCESORIOS

ACCESORIES

ACCESSOIRES

ACCESORIOS PARA MEDTROLLEYS / ACCESORIES FOR MEDTROLLEYS / ACCESSOIRES POUR MEDTROLLEY



Estructura tubular vertical con 4 cestas.
Vertical tubular structure with 4 cestas.
Structure verticale avec 4 paniers.

REF MED0030-A



Estructura con 2 cestas y dispensadores.
Structure with 2 baskets and titeld dispenser.
Structure avec 2 paniers et distributeurs.

REF MED0045-A



Base de conexión eléctrica.
Electrical connection base.
Base de connexion électrique.

REF MED0037



Estructura tubular vertical con 48 dispensadores de distinto tamaño.
Vertical tubular structure with 48 dispenser various sizes.
Structure tubulaire vertical avec 48 distributeurs de taille différente.

REF MED0047-A



Soporte desfibrilador o aparatos.
Desfibrillator support.
Desfibrillator pour défibrillateur.

REF MED0021



Doble soporte desfibrilador o aparatos.
Double defibrillator support.
Doubles support pour défibrillateur.

REF MED0036-A



Portasueros regulable de 2 ganchos.
Adjustable serum holder hooks.
Porte-sérum réglable 2 crochets.

REF MED0017



Portasueros regulable de 4 ganchos.
Adjustable serum holder 4 hooks.
Porte-sérum réglable 4 crochets.

REF MED0017-1

ACCESORIOS

ACCESSORIES

ACCESSOIRES

Consulte el CATÁLOGO de MEDTROLLEY para más información.

Consult the MEDTROLLEY CATALOGUE for more information.

Consultez le CATALOGUE DE MEDTROLLEY



Más accesorios en [página 35](#)



Portasero de 2 o 4 ganchos ABS.

Serum holder 2 or 4 hooks ABS.

Porte-sérum 2 or 4 crochets ABS.

(REF) OP002



Bloqueador de seguridad para cajones mediante precintos.

Blocking of drawers by seals.

Blocage tiroirs outsideof. Fixations de sécurité de tiroir bloc.

(REF) MED0015-01
MED0015-03



Estructura tubular vertical con 2 cestas.

Tubular structure vertical with 2 baskets.

Structure tubulaire vertical 2 paniers.

(REF) MED0029-A



Barandilla superior.

Upper railing. Galerie supérieure.

(REF) MED006-A



Bandeja lateral.

Lateral tray. Plateau latérale.

(REF) MED0035



Barandilla para bandeja lateral.

Railing for lateral tray. Galerie pour plateau latérale.

(REF) MED0012-A



Cajón basculante lateral transparente.

Tilted transparent drawer. Tiroir basculant transparent.

(REF) MED0013



Soporte charnela de pletina o varilla inox.

Drum support in stainless steel.

Support pour tambour.

(REF) MED001-A
MED001-2-A

carros

trolleys
chariots

medtrolley
serie / series/ série 800 / 900
serie / series/ série 1000
serie / series/ série 2000 MINI
serie / series/ série 2000

SERIE 800 / 900

SERIES

SÉRIE

Estructura fabricada en acero inoxidable AISI 304 18/10.

Structure made of stainless steel.
Structure en acier inoxydable.

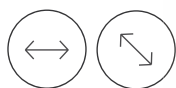

620x525 mm



FABRICADO
EN ACERO INOX.
AISI
304 18/10



Consulte el CATÁLOGO de CARROS HOSPITALARIOS para más información.

Consult the HOSPITAL TROLLEY CATALOGUE for more information.
Consultez le CATALOGUE DE CHARIOTS HOSPITALIERS pour en plus d'information.

Para solicitar su carro siga los siguientes pasos e indique / To request your trolley follow these steps and indicate / Pour demander votre chariot suivez les étapes ci dessous et indiquez :

1. REFERENCIA / REFERENCE / RÉFÉRENCE

2. ENCIMERA / WORTOP / PLAN DE TRAVAIL

-Acero inoxidable estándar / stainless steel standard / acier inoxydable.

-Para ABS. Indica / indicate / indiquer REF + "/ABS"

3. FRENTE DE CAJÓN / FRONTS / FAÇADES

Indica / indicate / indiquer REF +

-Para fenólico / phenolic / phénolique "- F "

-Para polietileno / polyethylene / polyéthylène "- P "

-Para metacrilato / methacrylate / métacrylate "- M "

-Acero inox. estándar / stainless steel / acier inox. "- A "

CARACTERÍSTICAS / FEATURES / CARACTÉRISTIQUES

TIRADORES / POUSSOIRS /
POUSSOIRS



RUEDAS DE Ø125 , 2 CON
FRENOS

WHEELS Ø125, 2 WITH BRAKES
ROUES Ø125, 2 AVEC Á FREINS



EMPUJADORES / PUSH / POIGNÉES



FRENTE Y PUERTAS / FRONTS AND DOORS / FAÇADES ET PORTES

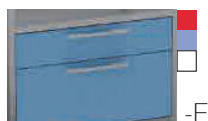

Fenólico
Phenolic
Phénolique



Metacrilato
Methacrylate
Métacrylate



Polietileno
Polyethylene
Polyéthylène



Acero Inoxidable
Stainless Steel
Acier Inoxydable

MÚLTIPLES CONFIGURACIONES Y ACCESORIOS DISPONIBLES / SEVERAL CONFIGURATIONS AND ACCESORIES ARE AVAILABLE / PLUSIEURS CONFIGURATIONS ET ACCESOIRES SONT DISPONIBLES

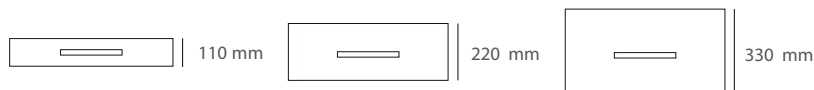

ENCIMERAS / WORKTOP / PLAN DE TRAVAIL



ACERO INOXIDABLE / STAINLESS
STEEL / ACIER INOXYDABLE
CON REBORDE DE 3 LADOS /
WITH RIMS ON 3 SIDES /
AVEC 3 BORDS RELEVÉS



ABS/ ABS / ABS

CON REBORDE DE 3 LADOS /
WITH RIMS ON 3 SIDES /
AVEC 3 BORDS RELEVÉS

MEDIDAS / DIMENSION / DIMENSION 620x525 mm

MEDIDAS / DIMENSION / DIMENSION 620x525 mm

carros
trolleys
chariots

medtrolley
serie / series/ série 800 / 900
serie / series/ série 1000
serie / series/ série 2000 MINI
serie / series/ série 2000

SERIE 800 / 900
SERIES
SÉRIE



M902



M900



M906



M911

990

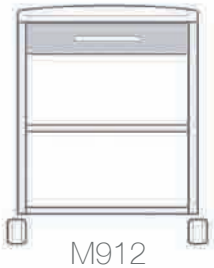

M912

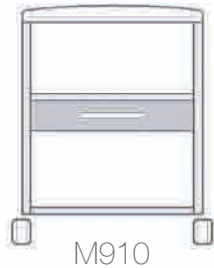

M910



M903

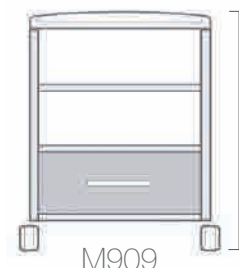

M909

990



M901



M880



M908

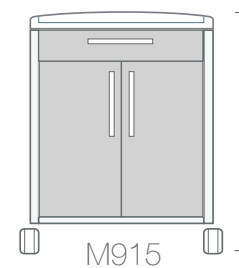

M915

990

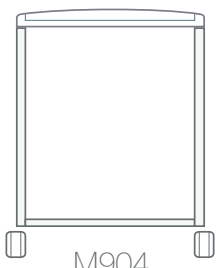

M904

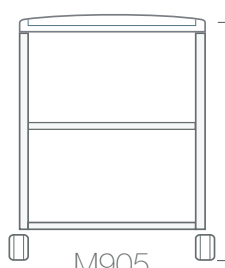

M905

990



M881

990



M882

990

carros

trolleys
chariots

medtrolley
ejemplos de modelos serie / series/ série 800 / 900
serie / series/ série 1000
serie / series/ série 2000 MINI
serie / series/ série 2000

M900-P



M900-P 620x525x990 mm

Acero inox. 18/10
Frente de cajón: polietileno
Colores estándar:
Azul, amarillo, verde, blanco y rojo

Consulte los colores disponibles

M902-F



M902-F 620x525x990 mm

Acero inox. 18/10
Frente de cajón: compacto fenólico
Colores estándar:
Blanco, rojo y celeste

Consulte los colores disponibles

M903/ABS-F



M903/ABS-F 620x525x1470 mm

Acero inox. 18/10
Frente de cajón: compacto fenólico
Colores estándar:
Blanco, rojo y celeste

Consulte los colores disponibles

M909-F



M909-F 620x525x990 mm

Acero inox. 18/10
Frente de cajón: compacto fenólico
Colores estándar:
Blanco, rojo y celeste

Consulte los colores disponibles

M910/ABS-P



M910/ABS-P 620x525x1015 mm

Acero inox. 18/10
Frente de cajón: polietileno
Colores estándar:
Azul, amarillo, verde, blanco y rojo

Consulte los colores disponibles

M911-P



M911-P 620x525x990 mm

Acero inox. 18/10
Frente de cajón: polietileno
Colores estándar:
Azul, amarillo, verde, blanco y rojo

Consulte los colores disponibles

carros

trolleys
chariots

medtrolley
 packs serie / series/ série 800 / 900
 serie / series/ série 1000
 serie / series/ série 2000 MINI
 serie / series/ série 2000

Pack M80



Pack M80 620x525x1340 mm

M882/ABS-P +

ACCESORIOS

- 1.OP888-11
- 2.OP888-5
- 3.OP888-35
- 4.M887
- 5.M885

Consulte los colores disponibles

Pack M81



Pack M81 620x525x1470 mm

M882-P +

ACCESORIOS

- 1.OP888-5
- 2.M888
- 3.M887
- 4.OP88-36
- 5.M885
- 6.OP888-11
- 7.OP888-28
- 8.OP888-34

Consulte los colores disponibles

Pack M82



Pack M82 620x525x990 mm

M906/ABS-P +

ACCESORIOS

- 1.OP888-3
- 2.OP888-34

Consulte los colores disponibles

Pack M83



Pack M83 620x525x1420 mm

M882/ABS-P +

ACCESORIOS

- 1.M887
- 2.M888
- 3.OP888-5
- 4.OP888-11

Consulte los colores disponibles

Pack M84



Pack M84 620x525x1340 mm

M906-P +

ACCESORIOS

- 1.M887
- 2.OP888-35
- 3.OP888-5
- 4.M885

Consulte los colores disponibles

Pack M85



Pack M85 620x525x1120 mm

M882/ABS-P +

ACCESORIOS

- 1.OP888-3
- 2.OP888-2
- 3.OP888-4
- 4.OP888-1
- 5.OP888-34

Consulte los colores disponibles

carros
trolleys
chariots

medtrolley
serie / series/ série 800 / 900
serie / series/ série 1000
serie / series/ série 2000 MINI
serie / series/ série 2000

SERIE 1000
SERIES
SÉRIE

Estructura fabricada en acero inoxidable AISI 304 18/10.

Structure made of stainless steel.
Structure en acier inoxydable.

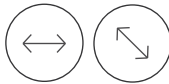

620x525 mm



FABRICADO EN ACERO INOX. AISI 304 18/10



Consulte el CATÁLOGO de CARROS HOSPITALARIOS para más información.

Consult the HOSPITAL TROLLEY CATALOGUE for more information.
Consultez le CATALOGUE DE CHARIOTS HOSPITALIERS pour en plus d'information.

Para solicitar su carro siga los siguientes pasos e indique / To request your trolley follow these steps and indicate / Pour demander votre chariot suivez les étapes ci dessous et indiquez :

1. REFERENCIA / REFERENCE / RÉFÉRENCE

2. ENCIMERA / WORTOP / PLAN DE TRAVAIL

- Acero inoxidable estándar / stainless steel standard / acier inoxydable.
- ABS. Indica / indicate / indiquer REF + "/ABS"

3. FRENTE DE CAJÓN / FRONTS / FAÇADES

Indica / indicate / indiquer REF +

- Fenólico / phenolic / phénolique "- F "
- Polietileno / polyethylene / polyéthylène "- P "
- Metacrilato / methacrylate / métacrylate "- M "
- Acero inox. estándar / stainless steel / acier inox. "- A "

CARACTERÍSTICAS / FEATURES / CARACTÉRISTIQUES

EMPUJADORES / PUSH / POIGNÉES



TIRADORES / POUSSOIRS / POUSSOIRS



RUEDAS DE Ø125 , 2 CON FRENOS

WHEELS Ø125, 2 WITH BRAKES
ROUES Ø125, 2 AVEC Á FREINS



OPCIÓN DE COLORES

OPTION COLORS
OPTION COULEURS



FRENTE Y PUERTAS / FRONTS AND DOORS / FAÇADES ET PORTES



Fenólico
Phenolic
Phénolique



Metacrilato
Methacrylate



Polietileno
Polyethylene
Polyéthylène



Acero Inoxidable
Stainless Steel
Acier Inoxydable

MÚLTIPLES CONFIGURACIONES Y ACCESORIOS DISPONIBLES / SEVERAL CONFIGURATIONS AND ACCESSORIES ARE AVAILABLE / PLUSIEURS CONFIGURATIONS ET ACCESSOIRES SONT DISPONIBLES

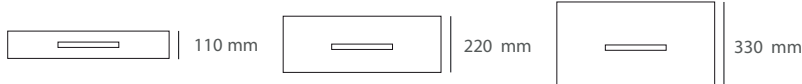

ENCIMERAS / WORKTOP / PLAN DE TRAVAIL



ACERO INOXIDABLE / STAINLESS STEEL / ACIER INOXYDABLE
CON REBORDE DE 3 LADOS / WITH RIMS ON 3 SIDES / AVEC 3 BORDS RELEVÉS



ABS/ ABS / ABS

CON REBORDE DE 3 LADOS / WITH RIMS ON 3 SIDES / AVEC 3 BORDS RELEVÉS

MEDIDAS / DIMENSION /DIMENSION 620x525 mm

MEDIDAS / DIMENSION /DIMENSION 620x525 mm

carros

trolleys
chariots

medtrolley

serie / series/ série 800 / 900

serie / series/ série 1000

serie / series/ série 2000 MINI

serie / series/ série 2000

SERIE 1000

SERIES

SÉRIE



M1006



M1007

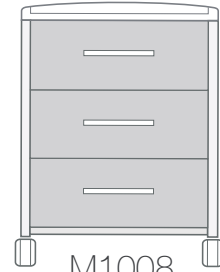

M1008

915



M1009



M1010



M1011

915



M1012



M1013



M1014

1025



M1015

1025



M1016

1135

Consulte el CATÁLOGO de CARROS HOSPITALARIOS para más información.

Consult the HOSPITAL TROLLEY CATALOGUE for more information.

Consultez le CATALOGUE DE CHARIOTS HOSPITALIERS pour en plus d'information.



carros

trolleys
chariots

medtrolley

serie / series/ série 800 / 900

ejemplos de modelos serie / series/ série 1000

serie / series/ série 2000 MINI

serie / series/ série 2000

SERIE 1000

SERIES

SÉRIE

M1010-P



M1010-P 620x525x890 mm

Acero inox. 18/10

Frente de cajón: polietileno

Colores estándar:

Azul, amarillo, verde, blanco y rojo



Consulte los colores disponibles

M1011-P



M1011-P 620x525x890 mm

Acero inox. 18/10

Frente de cajón: polietileno

Colores estándar:

Azul, amarillo, verde, blanco y rojo



Consulte los colores disponibles

M1007-ABS-F



M1007-ABS-F 620x525x915 mm

Acero inox. 18/10

Frente de cajón: compacto fenólico

Colores estándar:

Blanco, rojo y celeste



Consulte los colores disponibles

M1006-ABS-F



M1006-ABS-F 620x525x915 mm

Acero inox. 18/10

Frente de cajón: compacto fenólico

Colores estándar:

Blanco, rojo y celeste



Consulte los colores disponibles

M1008-A



M1008-A 620x525x890 mm

Acero inox. 18/10

Frente de cajón: compacto fenólico

Colores estándar:

Blanco, rojo y celeste



Consulte los colores disponibles

M1012-ABS-P



M1012-ABS-P 620x525x1025 mm

Acero inox. 18/10

Frente de cajón: polietileno

Colores estándar:

Azul, amarillo, verde, blanco y rojo



Consulte los colores disponibles

carros
trolleys
chariots

medtrolley
serie / series/ série 800 / 900
packs serie / series/ série 1000
serie / series/ série 2000 MINI
serie / series/ série 2000

SERIE 1000
SERIES
SÉRIE

Pack M10



Pack M10 620x525x000 mm

Pack M11



Pack M11 620x525x1320 mm

ACCESORIOS

- 1.OP888-3
- 2.OP888-4
- 3.OP888-2
- 4.OP888-34
- 5.OP888-11

M1010/ABS-P +

M1012/ABS-F +

- ACCESORIOS
- 1.OP888-26
 - 2.OP888-11

Consulte los colores disponibles

Consulte los colores disponibles

Pack M12



Pack M12 620x525x990 mm

M1008-P +

- ACCESORIOS
- 1.MED006-A
 - 2.MED007-A

Consulte los colores disponibles

Pack M13



Pack M13 620x525x1565 mm

ACCESORIOS

- 1.M887
- 2.M888
- 3.OP888-5
- 4.OP888-11
- 5.OP888-35

M1006-P +

Consulte los colores disponibles

Pack ME2



Pack ME2 620x525x1340 mm

ACCESORIOS

- 1.OP888-3
- 2.OP888-4
- 3.OP888-2
- 4.OP888-34
- 5.OP888-11
- 6.OP888-1

M1007/BS-P +

Consulte los colores disponibles

Pack MC2



Pack MC2 620x525x1120 mm

ACCESORIOS

- 1.M887
- 2.OP888-27
- 3.OP888-5
- 4.OP888-11

M1007/ABS-M +

Consulte los colores disponibles

carros

trolleys
chariots

serie / series / série 800 / 900
serie / series / série 1000
serie / series / série 2000 MINI
serie / series / série 2000

SERIE 2000 MINI SERIES

Estructura fabricada en acero inoxidable AISI 304 18/10.

Structure made of stainless steel.
Structure en acier inoxydable.

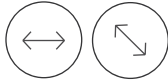

534x430 mm



FABRICADO
EN ACERO INOX.
AISI
304 18/10



Consulte el CATÁLOGO de CARROS HOSPITALARIOS para más información.

Consult the HOSPITAL TROLLEY CATALOGUE for more information.

Consultez le CATALOGUE DE CHARIOTS HOSPITALIERS pour en plus d'information.

Para solicitar su carro siga los siguientes pasos e indique / To request your trolley follow these steps and indicate / Pour demander votre chariot suivez les étapes ci dessous et indiquez :

1. REFERENCIA / REFERENCE / RÉFÉRENCE

2. FRENTE DE CAJÓN / FRONTS / FAÇADES

Indica / indicate / indiquer REF +

- Fenólico / phenolic / phénolique "- F "
- Polietileno / polyethylene / polyéthylène "- P "
- Metacrilato / methacrylate / métacrylate "- M "
- Acero inox. estándar / stainless steel / acier inox. "- A "

CARACTERÍSTICAS / FEATURES / CARACTÉRISTIQUES



EMPUJADOR / PULL
HANDLE / POIGNÉE



TIRADORES / POUSSOIRS /
POUSSOIRS



RUEDAS DE Ø125 , 2 CON
FRENOS
WHEELS Ø125, 2 WITH BRAKES
ROUES Ø125, 2 AVEC Á FREINS

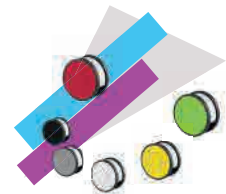

OPCIÓN DE COLORES
OPTION COLORS
OPTION COULEURS

CAJETINES MEDICACIÓN / MEDICATION BOXES / BOÎTES DE MÉDICAMENTS

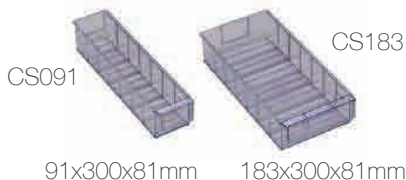

CS091

CS183

91x300x81mm

183x300x81mm

CESTAS / BASKETS / PANIERS



C050-45
450x400x50 mm



C100-45
450x400x100 mm

Múltiples configuraciones y accesorios disponibles.

Several configurations and accessories are available.
Plusieurs configurations et accessoires sont disponibles.



FRENTE Y PUERTAS / FRONTS AND DOORS / FAÇADES ET PORTES

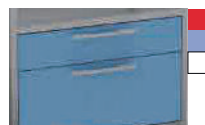

Fenólico
Phenolic
Phénolique



Metacrilato
Methacrylate
Métacrylate



Acero Inoxidable
Stainless Steel
Acier Inoxydable

carros

trolleys
chariots

serie / series / série 800 / 900

serie / series / série 1000

ejemplos carros serie / series / série 2000 MINI

serie / series / série 2000

SERIE 2000 MINI SERIES



M2001M-F



M2001M-F 534x430x990 mm

Acero inox. 18/10
Frente de cajon: fenólico
Colores estándar:

Blanco, rojo y celeste



Consulte los colores disponibles



M2002M-F



M2002M-F 534x430x990 mm

Acero inox. 18/10
Frente de cajon: fenólico
Colores estándar:

Blanco, rojo y celeste



Consulte los colores disponibles



M2003M-F



M2003M-F 534x430x990 mm

Acero inox. 18/10
Frente de cajon: fenólico
Colores estándar:

Blanco, rojo y celeste



Consulte los colores disponibles



M2004M-F



M2004M-F 534x430x990 mm

Acero inox. 18/10
Frente de cajon: fenólico
Colores estándar:

Blanco, rojo y celeste



Consulte los colores disponibles



M2005M-F



M2005M-F 534x430x990 mm

Acero inox. 18/10
Frente de cajon: fenólico
Colores estándar:

Blanco, rojo y celeste



Consulte los colores disponibles



M2006M-F



M2006M-F 534x430x990 mm

Acero inox. 18/10
Frente de cajon: fenólico
Colores estándar:

Blanco, rojo y celeste



Consulte los colores disponibles



M2007M-M



M2007M-F 534x430x990 mm

Acero inox. 18/10
Frente de cajon: metacrilato
Colores estándar:

Blanco, rojo y celeste



Consulte los colores disponibles



M2008M-A



M2008M-F 534x430x990 mm

Acero inox. 18/10
Frente de cajon: acero inox.
Colores estándar:

Gris



Consulte los colores disponibles



M2009M-F



M2009M-F 534x430x990 mm

Acero inox. 18/10
Frente de cajon: fenólico
Colores estándar:

Blanco, rojo y celeste



Consulte los colores disponibles

carros

trolleys
chariots

serie / series/ série 800 / 900
serie / series/ série 1000
serie / series/ série 2000 MINI
serie / series/ série 2000

SERIE 2000

SERIES

Consulte el CATÁLOGO de CARROS HOSPITALARIOS para más información.

Consult the HOSPITAL TROLLEY CATALOGUE for more information.

Consultez le CATALOGUE DE CHARIOTS HOSPITALIERS pour en plus d'information.



Estructura fabricada en acero inoxidable AISI 304 18/10.

Structure made of stainless steel.
Structure en acier inoxydable.

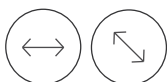

670x430 mm

FABRICADO EN ACERO INOX. AISI 304 18/10

Para solicitar su carro siga los siguientes pasos e indique / To request your trolley follow these steps and indicate / Pour demander votre chariot suivez les étapes ci dessous et indiquez :

1. REFERENCIA / REFERENCE / RÉFÉRENCE
2. ENCIMERA / WORTOP / PLAN DE TRAVAIL
-Acero inoxidable estándar / stainless steel standard / acier inoxydable.
- ABS. Indica / indicate / indiquer REF + "/ABS"
3. FRENTE DE CAJÓN / FRONTS / FAÇADES
Indica / indicate / indiquer REF +
-Fenólico / phenolic / phénolique "- F "
-Metacrilato / methacrylate / métacrylate "- M "
-Acero inox. estándar / stainless steel / acier inox. "- A "

CARACTERÍSTICAS / FEATURES / CARACTÉRISTIQUES

EMPUJADORES /
PUSH / POIGNÉES



TIRADORES / POUSSOIRS /
POUSSOIRS



RUEDAS DE Ø125 , 2 CON
FRENOS

WHEELS Ø125, 2 WITH BRAKES
ROUES Ø125, 2 AVEC Á FREINS



OPCIÓN DE COLORES

OPTION COLORS
OPTION COULEURS



FRENTE Y PUERTAS / FRONTS AND DOORS / FAÇADES ET PORTES



Fenólico
Phenolic
Phénolique



Metacrilato
Methacrylate



Acero Inoxidable
Stainless Steel
Acier Inoxydable

MÚLTIPLES CONFIGURACIONES Y ACCESORIOS DISPONIBLES / SEVERAL CONFIGURATIONS AND ACCESORIES ARE AVAILABLE / PLUSIEURS CONFIGURATIONS ET ACCESSOIRES SONT DISPONIBLES

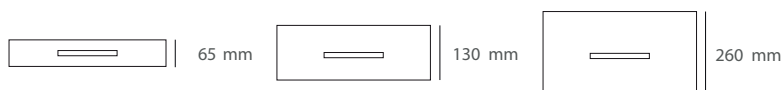

ENCIMERAS / WORKTOP / PLAN DE TRAVAIL



ACERO INOXIDABLE / STAINLESS
STEEL / ACIER INOXYDABLE
CON REBORDE DE 3 LADOS /
WITH RIMS ON 3 SIDES /
AVEC 3 BORDS RELEVÉS



ABS/ ABS / ABS

CON REBORDE DE 3 LADOS /
WITH RIMS ON 3 SIDES /
AVEC 3 BORDS RELEVÉS

MEDIDAS / DIMENSION / DIMENSION 620x525 mm

MEDIDAS / DIMENSION / DIMENSION 620x525 mm

CESTAS ISO 6040 / ISO 6040 BASKETS ISO / PANIERS ISO 6040



Complementos para cestas

Accessories for baskets

Accessoires pour paniers

Consultenos para más información.

Consult us for more information.

Consultez-nous pour en savoir plus

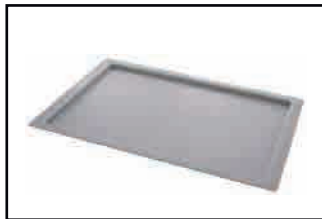

C015
ISO 600x400x15 mm



C050
ISO 600x400x50 mm



C100
ISO 600x400x100 mm



C200
ISO 600x400x200 mm

CAJETINES MEDICACIÓN / MEDICATION BOXES / BOÎTES DE MÉDICAMENTS



carros
trolleys
chariots

serie / series/ série 800 / 900
serie / series/ série 1000
serie / series/ série 2000 MINI
serie / series/ série 2000

SERIE 2000

SERIES



M2030/ABS-F



M2030/ABS-F 670x430x990 mm

Acero inox. 18/10
Frente de cajón: compacto fenólico
Colores estándar:
Blanco, rojo y celeste

Consulte los colores disponibles

M2012-M



M2000-F 670x430x1025 mm

Acero inox. 18/10
Frente de cajón: metacrilato
Colores estándar:
Blanco

Consulte los colores disponibles

M2000-AL-F



M2000-AL-F 670x430x1350 mm

Acero inox. 18/10
Frente de cajón: compacto fenólico
Colores estándar:
Blanco, rojo y celeste

Consulte los colores disponibles

M2017-F



M2017-F 670x430x940 mm

Acero inox. 18/10
Frente de cajón: compacto fenólico
Colores estándar:
Blanco, rojo y celeste

Consulte los colores disponibles

M2013-A



M2013-A 670x430x1000 mm

Acero inox. 18/10
Frente de cajón: acero inox.
Gris

M2000-ABS-F



M2000-ABS-F 670x430x940 mm

Acero inox. 18/10
Frente de cajón: compacto fenólico
Colores estándar:
Blanco, rojo y celeste

Consulte los colores disponibles

Pack M20



Pack M20 670x430x965 mm

M2024/ABS-F + ACCESORIOS
1.C050
2.CS091

Consulte los colores disponibles

Pack M21



Pack M21 670x430x1130 mm

M2000/ABS-P + ACCESORIOS
1.OP888-3
2.OP888-4
3.OP888-2
4.OP88-34
5.OP888-11
6.OP888-1

Consulte los colores disponibles

Pack M22



Pack M22 670x430x1130 mm

M2008-A + ACCESORIOS
1.OP888-3
2.OP888-4
3.OP888-2
4.OP88-34
5.OP888-11
6.OP888-1

Consulte los colores disponibles

Pack M23



Pack M23 670x430x1420 mm

M2004-F + ACCESORIOS
1.M887
2.M888
3.OP888-5
4.OP888-40
5.OP888-35

Consulte los colores disponibles

Pack M24



Pack M24 670x430x1420 mm

M2008-F + ACCESORIOS
1.M887
2.M888
3.OP888-5
4.OP888-11
5.OP888-36

Consulte los colores disponibles

Pack M25



Pack M25 670x430x1000 mm

M2000-M + ACCESORIOS
1.M885
2.OP888-11
3.OP888-5
4.OP888-35

Consulte los colores disponibles

carros

trolleys
chariots

unidosis / unit dosage / unidose
medicación / medication / médicaments

Carro UNIDOSIS

- _ Estructura en acero inoxidable. Encimera de acero inoxidable con 3 rebordes.
- _ Con cajones o puertas.
- _ Frontes de cajón en polietileno (-P), en fenólico (-F) o metacrilato (-M).
- _ Cajetines de 300x120x100mm. Se suministran con 3 separadores transparentes interiores y un juego de etiquetas. Los cajetines van colocados en filas de 4 unidades.
- _ Ruedas paralelas de Ø100 mm, con paragolpes, 2 con freno.
- _ Empujador lateral en acero inoxidable.
- _ Puertas de metacrilato transparente.
- _ Posibilidad de fabricar a medida.
- _ Cerradura opcional.

UNIT Dosage Trolleys

- _ Manufactured in stainless steel.
- _ Worktop in stainless steel, with rims in 3 sides.
- _ Drawers or doors.
- _ Front of drawers in stainless steel, polythene or phenolic resin.
- _ Doors in transparent methacrylate.
- _ Lateral push handle in stainless steel.
- _ 4 wheels Ø100 mm with bumpers, 2 with brakes.
- _ Boxes for medication, with dividers.
- _ Possibility of made to measure.
- _ Option: lock with key.

Chariots UNIDOSE

- _ Fabriqué en acier inoxydable.
- _ Plan de travail en acier inoxydable, avec des jantes à trois côtés.
- _ Avec tiroirs ou portes.
- _ Devant des tiroirs en acier inoxydable, polyéthylène ou de résine phénolique.
- _ Portes en méthacrylate transparent.
- _ Latéral pousser poignée en acier inoxydable.
- _ 4 roues Ø100 mm avec pare-chocs, 2 avec des freins.
- _ Boîtes pour medication, avec diviseurs.
- _ Possibilité faire comme.
- _ Choisir: serrure à clé.



M3216-P



M3212-A



M3032-PT

M3124-F+M885



CAJETINES PARA MEDICACIÓN / BOXES FOR MEDICATION / BOÎTES POUR MEDICATION

M3012



Fabricados en polímero color azul.
Incluye 1 juego de etiquetas y 4 separadores transparentes móviles. 300x120x100 mm (otras medidas consultar).

Made of blue polymer. 300x120x100 mm (consult other measures).
Includes 1 set of labels and 4 transparent movable dividers.

Fait de polymère bleu. 300x120x100 mm (consulter d'autres mesures).
Avec 1 set d'étiquettes et 4 diviseurs mobiles transparents.

REF



KG

| | | |
|--------------|-----------------|-------|
| M3216-P | 620x360x950 mm | 40 kg |
| M3212-A | 620x360x950 mm | 40 kg |
| M3124-F+M885 | 620x360x950 mm | 40 kg |
| M3032PT | 620x520x1050 mm | 60 kg |

carros

trolleys
chariots

unidadosis / unit dosage / unidose
medicación / medication / médicaments

Carros MEDICACIÓN

- _Fabricado en acero pintado epoxy, color blanco.
- _Barandilla en 3 lados
- _Encimera y frente de cajón en resina fenólica.
- Colores disponibles celeste, blanco y rojo.
- _Empujador lateral.
- _Ruedas poliamida Ø100 mm, 2 con freno.
- _2 modelos disponibles
 - M4020: Capacidad 20 bandejas (no incluidas).
 - M4040: Capacidad 40 bandejas (no incluidas).
- _Las bandejas se venden por separado.
- _Posibilidad de fabricación a medida.

MEDICATION Trolley

- _Made of painted steel, white color.
- _Railing on 3 sides.
- _Top and drawer front in phenolic resin.
- _Available colours: blue, white and red.
- _Lateral push handle.
- _4 polyamide wheels Ø100 mm, 2 with brakes.
- _2 models are available:
 - M4020: Capacity 20 trays (not included).
 - M4040: Capacity 40 trays (not included).
- _The trays are sold separately.
- _Possibility of made to measure.

Chariots de MÉDICAMENTS

- _Fabriqué en acier peint, couleur blanche.
- _Galerie sur 3 côtés.
- _Plan de travail et le tiroir en résine phénolique.
- _Couleurs disponibles bleu, blanc et rouge.
- _Poignée latéral.
- _Roues en polyamide Ø100 mm, 2 avec des freins.
- _2 modèles sont disponibles:
 - M4020: Capacité 20 plateaux (non inclus).
 - M4040: Capacité 40 plateaux (non inclus).
- _Les plateaux sont vendus séparément.
- _Possibilité fait sur mesure.

M4020



M4040



BANDEJAS DE MEDICACIÓN SEMANAL / WEEKLY MEDICATION TRAYS / PLATEAUX HEBDOMADAIRES



MB4000E

Fabricados en poliestireno azul. 407x245 mm.
Capacidad 7 dispensadores.
Cada dispensador tiene 4 compartimentos y tapa deslizante (disponible con etiqueta). Consulte otros modelos.

Made of blue polystyrene. 407x245 mm
Capacity: 7 dispensers.
Each dispenser have 4 compartments for the dailies and sliding lid (available with label). Consult another models.

Fait de polystyrene bleu. 407x245 mm
Capacité: 7 distributeurs.
Chaque distributeur a 4 compartiments pour les quotidiens, et couvercle coulissant (disponible avec étiquette). Des autres modèles disponibles.



| | | |
|-------|----------------|-------|
| M4020 | 480x390x810 mm | 30 kg |
| M4040 | 675x435x810 mm | 40 kg |

ACCESORIOS

ACCESSORIES

ACCESSOIRES



Tabla de parada en fenólico de 8 mm.

Cardiac massage board made of phenolic 8 mm.
Tableau d'urgence phénolique de 8mm.

(REF) OP888-2



Soporte desfibrilador en compacto fenólico.

Defibrillator support made of compact phenolic.
Support défibrillateur en phénolique.

(REF) OP888-4



Bloqueador exterior mediante precinto.

Blocking system by seals.
Fermeture pour scelle.

(REF) OP888-34



Base conexión eléctrica.

Electrical connection base.
Multiprise.

(REF) OP888-8



Porta bombonas de ajustes flexibles.

Oxygen bottle holder with flexible fitting.
Porte vérins réglages flexibles.

(REF) OP888-1



Rompe ampollas de acero inoxidable.

Ampoule opener in stainless steel.
Casse ampoule de acier inox.

(REF) MED0010-A



Sopòrte de caja de guantes.

Glove box holder.
Support de boîte de gants.

(REF) MED005-A

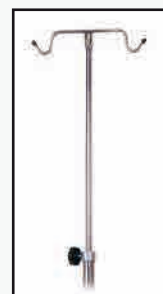

Porta suetos 2 ganchos.

Serum holder 2 hooks.
Porte serum 2 crochets.

(REF) OP888-3

Porta suetos 4 ganchos.

Serum holder 4 hooks.
Porte serum 4 crochets.

(REF) OP888-3-4

ACCESORIOS

ACCESSORIES

ACCESSOIRES

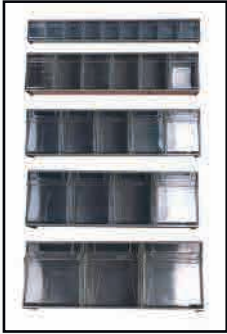

9 cajas basculantes M890.
9 tilted dispensers M890.
9 boîtes basculantes M890

6 cajas basculantes M888
6 tilted dispensers M888.
6 boîtes basculantes M888.

5 cajas basculantes M887.
5 tilted dispensers M887.
5 boîtes basculantes M887.

4 cajas basculantes M884.
4 tilted dispensers M884.
4 boîtes basculantes M884.

3 cajas basculantes M883.
3 tilted dispensers M883.
3 boîtes basculantes M883.



Bandeja acero inox para soporte.

Stainless steel tray.
Plateau en acier inoxydable pour support.

REF OP888-35



Soporte para sondas en acero inoxidable.

Catheter holder made of stainless steel.
Support pour sondes en acier inoxydable.

REF OP888-27



Estructura tubular para soportes o cajitas basculantes.

Tubular structure for supports or tilted dispenser.
Structure tubulaire pour support ou boîtes basculantes.

REF OP888-5



Riel superior para soporte de aparatos.

Upper rail to hang apparatus.
Rail supérieur pour support d'équipements.

REF OP888-36



Barandilla para estante.

Upper railing for shelf.
Galerie supérieur pour étagère.

REF OP888-10



Cesta 353x120x120
Basket 353x120x120
Panier 353x120x120

REF MCE350



Riel lateral para soporte aparatos en acero inox.

Side rail in stainless steel, to hang apparatus.
Rail lateral pour support d'équipements en acier inox.

REF OP888-28

ACCESORIOS

ACCESSORIES

ACCESSOIRES



Soporte para monitor.

Monitor support.
Fermeture pour scelle.

REF OP888-38



Balda extraíble mediante guías telescópicas.

Sliding shelf by telescopic guides.
Tablette coulissante par guides

REF OP888-26



Balda extraíble mediante guías telescópicas para PC.

Sliding shelf by telescopic guides for PC.

REF OP888-26-L



Bandeja lateral abatible de acero inoxidable.

Collapsible auxiliary board in stainless steel.
Plateau latéral à abatants en acier

REF M885



REF MED0022

Separadores de cajones 800, 900 y 1000.

Drawer dividers for series 800, 900 and 1000.
Diviseurs de tiroirs 800, 900 et 1000.

REF MED0024



Módulo lateral con 3 huecos.

Side module with 3 holes.
Module latérales avec 3 espaces.

REF OP888-40



Porta etiquetas.

Label holder.
Porte étiquettes.

REF OP888-29

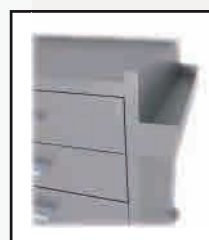

Bandeja lateral en acero inoxidable.

Side stainless steel tray.
Plateau latéral en acier inox.

REF OP888-7



Consulte el Catálogo de Carros Hospitalarios para más información.
Consult the Hospital Trolley Catalog for more information.
Consultez le Catalogue de Chariots Hospitaliers pour plus d'informaiton.



Soporte charnela de varilla en acero inox.

Dressing drum rod support in stainless steel.
Soutien pour tambour de soins.

(REF) MED001-2A



Soporte suspendido para palangana (incluida).

Hanged support for basin (included).
Support suspendu pour bassine (inclus).

(REF) MED0011-A



Reborde frontal para encimera de acero.

Front raised edge for stainless steel upper tray.
Rebord frontal pour plan de travail en acier inox.

(REF) OP888-30

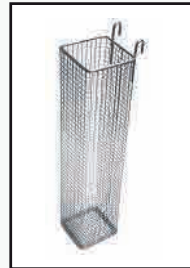

Cesta porta sondas.

Catheter basket.
Panier pour cathéter

(REF) MB180C



Papelera basculante de PVC. Capacidad de 10L.

Wastebasket in PVC with tilted cover. Capacity 10L.
Poubelle basculant de PVC. Capacité de 10L.

(REF) OP888-11



Papelera en acero inox. 10L.

Wastebasket in stainless steel. Capacity 10L.
Poubelle de acier inox. Capacité de 10L.

(REF) OP888-0



Dosificador jabón accionado por codo.

Elbow operated soap dispenser.
À commande au coude.

(REF) M889-P



Soporte de bolsas

Bag holders support.
Support de sac.

(REF) FM00132



carros varios usos

trolleys

chariots

carros

trolleys
chariots

curas / dressing / soins
escayolas / plaster / platres
distribución / distribution / distribution

Carro de CURAS 2 BANDEJAS

M096-C

- _Fabricado en acero inoxidable AISI 304 18/10.
- _2 bandejas desmontables. Opción: soporte lateral.
- _Papelera lateral con tapa basculante.
- _Empujadores de plástico.
- _Ruedas Ø80 mm con paragolpes, 2 con freno.

🇬🇧 DRESSING Trolley

- _Manufactured in stainless steel AISI 304 18/10.
- _2 removable trays. Option: lateral support.
- _Waste bin with lid.
- _Castors Ø80 mm, 2 with brakes and bumpers.
- _Plastic handles.

🇫🇷 Guéridon de SOINS

- _Fabriqué en acier inoxydable AISI 304 18/10.
- _2 panneaux amovibles. Option: support latéral.
- _Poubelle en plastique.
- _Roulettes Ø80 mm, avec parechocs, dont 2 avec freins.
- _Poignées en plastique.



M096-C

600x400x800 mm

10 kg

Carro de CURAS

M051

- _Fabricado en acero inoxidable AISI 304 18/10.
- _2 estantes lisos. Estante superior con barandilla en 3 lados. Disponible modelo con bandeja superior (M051-B).
- _2 cajones pequeños.
- _Soporte lateral para caja de guantes, bombonas portacuras...
- _Papelera lateral con tapa basculante.
- _Empujadores de plástico.
- _Ruedas Ø80 mm con paragolpes, 2 con freno.

🇬🇧 DRESSING Trolley

- _Manufactured in stainless steel AISI 304 18/10.
- _2 smooth shelves. Upper shelf with railing on 3 sides. Available model with top tray (M051-B).
- _2 small drawers. Lateral support for dressing drums, gloves boxes.
- _Removable wastebin with lid.
- _Ø80 mm castors, 2 with brakes, with bumpers.
- _Plastic handles.

🇫🇷 Guéridon de SOINS

- _Fabriqué en acier inoxydable AISI 304 18/10.
- _2 étagères fixes. Étagère supérieure avec galerie sur 3 côtés. Disponible modèle avec une plateau supérieure (M051-B).
- _2 petites tiroirs.
- _Support latéral pour tambours, gants boîtes.
- _Poubelle amovible en plastique.
- _Roulettes Ø80 mm, dont 2 avec freins, avec parechocs.
- _Poignées en plastique.



Bandeja extraíble.



M051

830x400x850 mm

17 kg

M051-B

830x400x850 mm

17 kg

Estante

Bandeja extraíble

carros

trolleys
chariots

curas / dressing / soins
escayolas / plaster / platres
distribución / distribution / distribution

Carro de CURAS

M053

- _Fabricado en acero esmaltado (M050) o inoxidable (M053).
- _Parte superior con 2 bandejas desmontables en acero inoxidable.
- _Parte inferior con estante fijo.
- _Soporte lateral y cubo para restos desmontable, en acero inoxidable.
- _Empujadores de plástico.
- _Ruedas Ø80 mm con paragolpes, 2 con freno.

🇬🇧 DRESSING Trolley

- _Manufactured in stainless steel (M053) or enamelled (M050).
- _Two removable upper stainless steel trays. Lower fixed shelf.
- _Lateral support for dressing drums, gloves boxes.
- _Removable wastebin in stainless steel.
- _Castors Ø80 mm, 2 with brakes, with bumpers.
- _Plastic handles.

🇫🇷 Guéridon de SOINS

- _Fabriqué en acier inoxydable (M053) ou peint (M050).
- _Partie supérieure avec 2 plateaux amovibles en acier inoxydable.
- _Partie inférieure avec étagère fixe.
- _Support latéral et poubelle amovible en acier inoxydable.
- _Roulettes Ø80 mm, dont 2 avec freins.
- _Poignées en plastique.



| REF | ↔ ↻ ↕ | KG | Acabado |
|------|----------------|-------|-------------|
| M053 | 980x450x800 mm | 17 kg | Acero Inox. |
| M050 | 980x450x800 mm | 17 kg | Esmaltado |

Carro de CURAS

M052

- _Fabricado en acero inoxidable AISI 304 18/10.
- _Parte superior con 2 bandejas desmontables en acero inoxidable.
- _Parte inferior con 1 bandeja desmontable de acero inoxidable.
- _Soporte lateral y cubo para restos desmontable, en acero inoxidable.
- _Ruedas Ø80 mm con paragolpes, 2 con frenos.
- _Empujadores de plástico.

🇬🇧 DRESSING Trolley

- _Manufactured in stainless steel AISI 304 18/10.
- _Removable stainless steel trays.
- _Lateral support for dressing drums, gloves boxes.
- _Removable wastebin in stainless steel.
- _Castors Ø80 mm, 2 with brakes, with bumpers.
- _Plastic handle.

🇫🇷 Guéridon de SOINS

- _Fabriqué en acier inoxydable AISI 304 18/10.
- _3 plateaux amovibles en acier inoxydable.
- _Support latéral et poubelle amovible en acier inoxydable.
- _Roulettes Ø80 mm, dont 2 avec freins, with parechocs.
- _Poignées en plastique.



| REF | ↔ ↻ ↕ | KG |
|------|----------------|-------|
| M052 | 980x450x800 mm | 17 kg |

carros

trolleys
chariots

curas / dressing / soins
escayolas / plaster / platres
distribución / distribution / distribution

Carro para ESCAYOLA

- _Fabricado en acero inoxidable.
- _Tablero abatible.
- _Empujadores de plástico.
- _Ruedas Ø125 mm con paragolpes, 2 con freno.
- _Cubeta extraíble de acero inoxidable (capacidad 8L).
- _Compartimento inferior con tapa.
- _Modelo simple o doble.

🇬🇧 PLASTER Trolley

- _Structure made of stainless steel.
- _Collapsible side shelf.
- _Plastic handles.
- _Wheels Ø125 mm with bumpers, 2 with brakes.
- _Stainless steel basin (8L capacity).
- _Lower compartment with lid.
- _Simple or double model.

🇫🇷 Gueridon pour PLATRES

- _Fabrication en acier inoxydable.
- _Panneau abattable.
- _Poignés en plastique.
- _Roulettes de Ø125 mm avec pare-chocs, 2 à frein.
- _Cuvette amovible en acier inoxydable (capacité 8L).
- _Compartiment inférieur avec couvercle.
- _Modèle simple ou double.

M071



M071-1



REF



KG

| | | | |
|--------|---------------------|-------|--------|
| M071 | 1000x500-850x900 mm | 35 kg | DOBLE |
| M071-1 | 380x500-830x970 mm | 22 kg | SIMPLE |

Carros para cestas

- _Fabricados en acero inox AISI 304 18/10.
- _4 ruedas Ø125mm con paragolpes, 2 con freno
- _Diseñados para soportar grandes cargas.
- _Varios modelos disponibles.

🇬🇧 Trolleys FOR BASKETS

- _Manufactured in stainless steel AISI 304 18/10.
- _4 wheels Ø125mm with bumpers, 2 with brakes.
- _Designed to support heavy load.
- _Several available models.

🇫🇷 CHARRIOTS de paniers

- _Construit en acier inoxydable AISI 304 18/10.
- _4 roulettes Ø125mm avec pare-chocs, 2 à frein.
- _Conçu pour soutenir une charge lourde.
- _Plusieurs modèles disponibles.

MLA103



MLA102



MLA101



REF



KG
máx

| | | |
|--------|------------------|--------|
| MLA101 | 520x520x250 mm | 80 kg |
| MLA102 | 731x634x1050 mm | 80 kg |
| MLA103 | 1040x640x1050 mm | 300 kg |

carros

trolleys
chariots

distribución / distribution / distribution
porta-contenedores / containers / récipient
ropa limpia y sucia / linen-laundry / linge propre et sale

Carros de DISTRIBUCIÓN

- _Fabricado en acero inoxidable.
- _Disponible con 2 (M075-2), 3 (M075) o 4 (M075-4) estantes.
- _4 ruedas Ø125 mm con paragolpes, 2 con freno.

DISTRIBUTION Trolleys

- _Manufactured in stainless steel.
- _Available with 2 (M075-2), 3 (M075) or 4 (M075-4) smooth shelves.
- _Wheels Ø125 mm with bumpers, 2 with brakes.

Guéridons de DISTRIBUCION

- _Construit en acier inoxydable.
- _2 (M075-2), 3 (M075) ou 4 (M075-4) étagères.
- _Roulettes Ø125 mm avec pare-chocs, dont 2 à frein.



M075



M075-4



M075-2

| REF |  | KG |
|--------|---|-------|
| M075-2 | 950x500x950 mm | 20 kg |
| M075 | 950x500x950 mm | 23 kg |
| M075-4 | 950x500x1200 mm | 26 kg |

Carro PORTA CAJAS INSTRUMENTAL

- _Fabricado en acero inoxidable.
- _Estructura en tubo cuadrado reforzado.
- _6 estantes.
- _4 ruedas Ø125 mm con paragolpes, 2 con freno.

INSTRUMENTS BOXES Trolley

- _Manufactured in stainless steel.
- _Reinforced frame, square tube.
- _6 smooth shelves.
- _Wheels Ø125 mm with bumpers, 2 with brakes.

Guéridon pour BOÎTES D'INSTRUMENTAL

- _Construit en acier inoxydable.
- _Structure en tube carré renforcé.
- _6 étagères.
- _Roulettes Ø125 mm avec pare-chocs, dont 2 à frein.



M075-6

| REF |  | KG |
|--------|---|-------|
| M075-6 | 1000x600x1450 mm | 30 kg |

carros

trolleys
chariots

distribución / distribution
porta-contenedores / containers / récipient
ropa limpia / clean linen / linge propre

Carro de DISTRIBUCIÓN

- _Fabricado en acero inoxidable.
- _Disponible con 2 (M075-B2), 3 (M075-B) o 4 (M075-B4) bandejas fijas de 900x500 mm.
- _4 ruedas Ø125 mm con paragolpes, 2 con freno.

🇬🇧 DISTRIBUTION Trolley

- _Manufactured in stainless steel.
- _Available with 2 (M075-B2), 3 (M075-B) or 4 (M075-B4) fixed trays, 900x500 mm.
- _Wheels Ø125 mm with bumpers, 2 with brakes.

🇫🇷 Guéridon de DISTRIBUCIÓN

- _Construit en acier inoxydable.
- _2 (M075-B2), 3 (M075-B) ou 4 (M075-B4) panneaux de 900x500 mm.
- _Roulettes Ø125 mm avec pare-chocs, dont 2 à frein.



REF



KG

| | | |
|---------|-----------------|-------|
| M075-B | 950x500x950 mm | 23 kg |
| M075B-2 | 950x500x950 mm | 20 kg |
| M075B-4 | 950x500x1200 mm | 26 kg |

Carros DISTRIBUCIÓN

- _Fabricado en polietileno.
- _3 estantes con reborde.
- _Asideros a ambos lados, para facilitar el desplazamiento.
- _4 ruedas, 2 con frenos.
- _Posibilidad de incorporar cubos a los lados.
- _2 colores disponibles.

🇬🇧 DISTRIBUTION Trolley

- _Made of polyethylene.
- _3 shelves with lips.
- _Handles on both sides, to facilitate the displacement.
- _4 wheels.
- _Possibility of adding bins to the sides.
- _Available in 2 colors.

🇫🇷 Guéridon de DISTRIBUCIÓN

- _Fabriqué en polyéthylène.
- _3 étagères avec des bords. èvres.
- _Poignées sur les 2 côtés, pour faciliter le déplacement.
- _4 roues dont 2 avec freins.
- _Possibilité d'ajouter des bacs sur les côtés.
- _2 couleurs disponibles.



REF



KG

| | | |
|---------|-----------------|-------|
| M075-PG | 1020x500x960 mm | 20 kg |
| M075-PP | 845x430x950 mm | 18 kg |

carros

trolleys
chariots

porta-contenedores / container / récipient
ropa limpia / clean linen / linge propre
ropa limpia y sucia / linen-laundry / linge propre et sale

Carro PORTA-CONTENEDORES

M498

- _Fabricado en acero inoxidable.
- _Estructura en tubo cuadrado reforzado.
- _3 estantes.
- _4 ruedas Ø125 mm con paragolpes, 2 con freno.

CONTAINERS Trolley

- _Manufactured in stainless steel.
- _Reinforced frame, square tube.
- _3 smooth shelves.
- _Wheels Ø125 mm with bumpers, 2 with brakes.

Guéridon pour CONTAINERS

- _Construit en acier inoxydable.
- _Structure en tube carré renforcé.
- _3 étagères.
- _Roulettes Ø125 mm avec pare-chocs, dont 2 à frein.



| | | |
|------|----------------|-------|
| REF | ↔ ↙ ↕ | KG |
| M498 | 950x500x900 mm | 30 kg |

Carro de ROPA LIMPIA

M061

- _Fabricado en acero inoxidable.
- _3 estantes de 900x500 mm.
- _4 ruedas Ø125 mm con paragolpes, 2 con freno.
- _Disponible modelo cerrado con puertas abatibles y estante interior (Mo61-C)

CLEAN LINEN Trolley

- _Stainless steel construction.
- _3 smooth shelves.
- _Closed model: 2 doors and inner shelf (Mo61-C).
- _Wheels Ø125 mm with bumpers.

Guéridon de LINGE PROPE

- _Construit en acier inoxydable.
- _3 étagères lisses de 900x500 mm.
- _Roulettes Ø125 mm avec pare-chocs, dont 2 à frein.
- _Version fermée: 2 portes et 1 étagère.

M061-C



| | | |
|--------|-----------------|-------|
| REF | ↔ ↙ ↕ | KG |
| M061 | 950x500x1200 mm | 24 kg |
| M061-C | 950x500x950 mm | 35 kg |

carros

trolleys
chariots

ropa limpia / clean linen / linge propre
ropa limpia y sucia / linen-laundry / linge propre et sale
ropa sucia / laundry / linge sale

Carros de ropa LIMPIA Y SUCIA

M068

- _Fabricado en acero inoxidable.
- _Con 3 estantes y un saco de lona lavable (color azul).
- _Ruedas Ø125 mm con paragolpes, 2 con freno.
- _Empujador de plástico.

LINEN-LAUNDRY Trolley

- _Manufactured in stainless steel.
- _3 shelves and one washable linen bag (blue colour).
- _Wheels Ø125 mm with bumpers, 2 with brakes.
- _Plastic handles.

Chariot de LINGE PROPE ET SALE

- _Construit en acier inoxydable.
- _3 étagères et sac de toile lavable (couleur bleue).
- _Roulettes Ø125 mm avec pare-chocs.
- _Poignées en plastique.



M068

950x500x1110 mm

18 kg

Carros de ropa LIMPIA Y SUCIA

M069

- _Fabricado en acero inoxidable.
- _Bandeja superior con reborde en 4 lados y 3 estantes lisos.
- _2 sacos de gran tamaño, en lona lavable (color azul).
- _Empujadores a ambos lados.
- _Ruedas Ø125 mm con paragolpes, 2 con freno.
- _Paragolpes de goma en los extremos.

LINEN / LAUNDRY Trolley

- _Manufactured in stainless steel.
- _Upper tray with bords and 3 shelves.
- _2 washable linen bags (blue colour) of great size.
- _Handles in stainless steel on both sides.
- _Wheels Ø125 mm, 2 with brakes.
- _Rubber bumper on each side.

Chariot de LINGE PROPE ET SALE

- _Construit en acier inoxydable.
- _Plateau supérieur avec bords et 3 étagères.
- _2 sacs de toile lavables (couleur bleue) de grande taille.
- _2 poignées en acier inoxydable.
- _Pare-chocs en caoutchouc sur les côtés.
- _Roues Ø125 mm, 2 avec freins.



M069

1420x500x1124 mm

42 kg

carros

trolleys
chariots

ropa limpia y sucia / linen-laundry / linge propre et sale
ropa sucia / laundry / linge sale
historias clínicas / files / dossiers

Carro de ROPA LIMPIA Y SUCIA

M069-B

- _Fabricado en acero inoxidable.
- _Bandeja superior con reborde en 4 lados. Divisores opcionales.
- _4 estantes lisos.
- _2 sacos de gran tamaño, plastificadas, color azul.
- _Asas telescópicas en ambos lados.
- _Ruedas Ø 160 mm, 2 con freno.
- _Paragolpes de goma alrededor.

LINEN-LAUNDRY Trolleys

- _Manufactured in stainless steel.
- _Upper tray with 4 bords. Optional dividers.
- _4 smooth shelves.
- _2 washable linen bags (blue colour) of great size.
- _Telescopic handles in stainless steel on both sides.
- _Wheels Ø160 mm, 2 with brakes.
- _Rubber bumper around trolley.

Chariot de LINGE PROPE ET SALE

- _Construit en acier inoxydable.
- _Plateau supérieur avec bords. Sérapateurs optionnels.
- _4 étagères lisses.
- _2 sacs de toile lavables (couleur bleue) de grande taille.
- _2 poignées télescopiques en acier inoxydable.
- _Roues Ø160 mm, 2 avec freins.
- _Pare-chocs en caoutchouc.



REF



KG

M069-B

1450x640x1200 mm

35 kg

Carro de ROPA LIMPIA Y SUCIA

M069-C

- _Fabricado en acero inoxidable. 4 bandejas en polipropileno color gris.
- _2 sacos de gran tamaño, plastificadas de gran tamaño, color azul.
- _Asas telescópicas en ambos lados.
- _Ruedas Ø125 mm con paragolpes, 2 con freno.

LINEN-LAUNDRY Trolleys

- _Manufactured in stainless steel. 4 trays in polypropylene, grey colour.
- _2 washable linen bags (blue colour) of great size.
- _Telescopic handles in stainless steel on both sides.
- _Wheels Ø125 mm with bumpers, 2 with brakes.

Chariot de LINGE PROPE ET SALE

- _Construit en acier inoxydable. 4 plateaux en polipropilene, couleur gris.
- _2 sacs de toile lavables (couleur bleue) de grande taille.
- _2 poignées télescopiques en acier inoxydable.
- _Roues Ø125 mm avec pare-chocs, 2 avec freins.



REF



KG

M069-C

1000x560x1280 mm

15 kg

carros

trolleys
chariots

ropa sucia / laundry / linge sale
historias clínicas / files / dossiers
endoscopia / endoscopy / endoscopie

Carro de ROPA SUCIA

- _Fabricado en acero inoxidable AISI 304 18/10.
- _Saco de lona lavable (color azul).
- _Ruedas Ø80 mm con paragolpes, 2 con freno.
- _Asidero lateral de plástico.
- _Disponible en versión simple o doble.

🇬🇧 SAL holder

- _Manufactured in stainless steel AISI 304 18/10.
- _Washable linen bag (blue colour).
- _Plastic handles.
- _Wheels Ø80 mm with bumpers, 2 with brakes.
- _Available simple or double model.

🇫🇷 POUR sacs

- _Construit en acier inoxydable AISI 304 18/10.
- _Sac de toile lavable (couleur bleue).
- _Tireurs en plastique.
- _Roulettes Ø80 mm avec pare-chocs, dont 2 à frein.
- _Disponible simple ou double.



| REF | ↔ ↻ ↕ | KG |
|------|-----------------|-------|
| M064 | 550x500x1000 mm | 12 kg |
| M065 | 800x500x1000 mm | 26 kg |

Carro de ROPA SUCIA

- _Fabricado en acero inoxidable para bolsa de plástico estándar.
- _Ruedas Ø80 mm con paragolpes, 2 con freno.
- _Disponible en versión simple o doble.

🇬🇧 LAUNDRY Trolley

- _Manufactured in stainless steel. For standar plastic bag.
- _Wheels Ø80 mm with bumpers, 2 with brakes.
- _Available simple or double model.

🇫🇷 Guéridon de LINGE SALE

- _Construit en acier inoxydable. Pour sac de plastique standar.
- _Roulettes Ø80 mm avec pare-chocs, dont 2 à frein.
- _Disponible simple ou double.



| REF | ↔ ↻ ↕ | KG |
|--------|-----------------|-------|
| M067 | 400x400x800 mm | 15 kg |
| M067-2 | 800x400x800 mm | 30 kg |
| M067-3 | 1200x400x800 mm | 40 kg |

carros

trolleys
chariots

ropa sucia / laundry / linge sale
historias clínicas / files / dossiers
endoscopia / endoscopy / endoscopie

Carro de ROPA SUCIA

_Carro con soporte bolsa, con tapa y bandeja de polipropileno con pedal, estructura cromada o de acero inoxidable (opcional).

_4 ruedas de Ø 75 mm (una con freno).

_Saco de lona opcional.

_Disponible: simple, doble y triple.

🇬🇧 LAUNDRY Trolley

_Bag holder trolley with polypropylene cover and pedal-operated lid.

_Chrome-plated or stainless steel structure (optional).

_4 x Ø 75 mm wheels (one with brake).

_Optional canvas bag.

_Available: simple, double and triple.

🇫🇷 Guéridon de LINGE SALE

_Construit en acier inox chromé avec pédal (optionnel).

_Support de sac, couvercle et plateau en propilene, avec pedal

_4 roulettes de Ø 75 mm (une avec frein).

_Sac de toile en option.

_Disponibles : single, doubles et triples.



REF



KG

| | | |
|---------|-----------------|-------|
| M067-1P | 510x500x970 mm | 7 kg |
| M067-2P | 1010x500x970 mm | 14 kg |
| M067-3P | 1510x500x970 mm | 20 kg |

Carro de HISTORIAS CLÍNICAS

M245I

_Estructura en acero inoxidable AISI 304 18/10.

_Patas reforzadas.

_Estante inferior.

_2 empujadores laterales de plástico.

_Ruedas Ø80 mm, con paragolpes, 2 con freno.

_Cerradura con llave.

_Capacidad para 50 carpetas (no incluidas) MD51020

🇬🇧 FILES Trolley

_Stainless steel structure AISI 304 18/10..

_Reinforced legs.

_Lower shelf.

_2 plastic handles.

_Wheels Ø80 mm with bumpers, 2 with brakes.

_Lock with key.

_Capacity: 50 folders (not included) MD51020

🇫🇷 Chariot pour DOSSIERS CLINIQUES

_Construit en acier inoxydable AISI 304 18/10.

_Avec jambes renforcés.

_Tireurs en plastique.

_Roulettes Ø80 mm avec pare-chocs, 2 à frein.

_Avec serrure a clés.

_Capacité: 50 chemises (non incluses) MD51020



REF



KG

| | | |
|---------|----------------|-------|
| M245I | 700x550x950 mm | 19 kg |
| MD51020 | 46x36 mm | |

carros

trolleys
chariots

ropa sucia / laundry / linge sale
historias clínicas / files / dossiers
endoscopia / endoscopy / endoscopie

Carro de HISTORIAS CLÍNICAS

M245I-E

- _Estructura en acero inoxidable AISI 304 18/10..
- _Estructura reforzada.
- _Empujador superior en acero inoxidable.
- _Ruedas Ø125 mm , 2 con freno.
- _2 estantes.

🇬🇧 FILES Trolley

- _Stainless steel structure AISI 304 18/10.
- _Reinforced structure.
- _Upper handle in stainless steel.
- _Wheels Ø125 mm, 2 with brakes.
- _2 shelves.

🇫🇷 Chariot pour DOSSIERS CLINIQUES

- _Construit en acier inoxydable AISI 304 18/10.
- _Avec structure renforcé.
- _Tireur supérieur en acier inoxydable
- _Roulettes Ø125 mm, 2 à frein.
- _2 étagères.



M245I-E

500x470x1070 mm

19 kg

Carro de HISTORIAS CLÍNICAS

M245-IA

- _Estructura en acero inoxidable y resina fenólica.
- _Empujador superior en acero inoxidable.
- _Separadores verticales para carpetas AZ.
- _Hueco inferior para sobres o carpetas.
- _Ruedas paralelas Ø100 mm con paragolpes, 2 con freno.

🇬🇧 FILES Trolley

- _Structure made of stainless steel and phenolic resin.
- _Upper handle in stainless steel.
- _Vertical dividers for folders AZ size.
- _Lower hollow for envelope or folders.
- _Parallel wheels Ø100 mm with bumpers, 2 with brakes.

🇫🇷 Chariot pour DOSSIERS CLINIQUES

- _Construit en acier inoxydable et résine phénolique.
- _Tireur supérieur en acier inoxydable.
- _Séparateurs verticaux pour dossiers AZ.
- _Creux inférieur pour enveloppes or dossiers.
- _Roulettes parallèles Ø100 mm avec pare-chocs, 2 à frein.



M245-IA

535x400x1125 mm

43 kg

carros

trolleys
chariots

endoscopia / endoscopy / endoscopie
transporte cadaver / cadaver / cadavres
transporte / stretcher / brancard

Carro de ENDOSCOPIA

M2000-ALG-E

- _Fabricado en acero inoxidable AISI 304 18/10.
- _Encimera con reborde en 3 lados.
- _Ruedas paralelas de poliamida de Ø100 mm, 2 con freno.
- _Puertas en resina fenólica.
- _Trasera con orificios y base de conexión eléctrica.
- _Par de guías extraíbles con 8 ganchos cada una.
- _Un estante y 2 cestas ISO (600x400x100 mm), extraíbles.

ENDOSCOPY Trolley

- _Structure made of stainless steel AISI 304 18/10.
- _Worktop with rim on 3 sides.
- _Parallel wheels Ø100 mm, 2 with brakes.
- _2 doors in phenolic.
- _Rear side with holes for ventilation, and electrical connection base.
- _Pair of guides, extractable, with 8 hooks each.
- _One shelf, and 2 ISO baskets (600x400x100 mm), removable.

Chariot d' ENDOSCOPIE

- _Structure en acier inox AISI 304 18/10.
- _Plan de travail avec rebord sur 3 côtés.
- _Roues parallèles Ø100 mm, dont 2 avec freins.
- _Deux portes en phénoliques.
- _Face arrière avec des trous pour la ventilation, et la base de connexion électrique.
- _Paire de guides, extractibles, avec 8 crochets chacune.
- _Une tablette, et 2 paniers ISO (600x400x100 mm), amovible.



M2000-ALG-E 670x430x1650 mm 60 kg

Carro TRANSPORTE CADÁVER

M041

- _Fabricado en acero inoxidable AISI 304 18/10.
- _4 ruedas Ø125 mm, 2 con freno.
- _Estructura reforzada.
- _Lecho desmontable.
- _Lona plastificada.
- _Disponible con lecho curvo.

CADAVER Trolley

- _Manufactured in stainless steel AISI 304 18/10.
- _4 wheels Ø125 mm, 2 with brakes.
- _Reinforced frame.
- _Removable bed.
- _Plastic canvas.
- _Available with curved bed.



Chariot pour CADAVRES

- _Bâti en acier inoxydable AISI 304 18/10.
- _4 roues Ø125 mm, dont 2 avec freins.
- _Structure renforcé.
- _Lit démontable.
- _Toile plastifié.
- _Disponible avec lit courbe



M041-C



M041 1950x600x850 mm 30 kg
M041-C 1950x600x850 mm 32 kg

carros

trolleys
chariots

transporte cadaver / cadaver / cadavres

transporte / stretcher / brancard

carros porta-cestas / trolleys carrying baskets / portant des paniers

Carro de TRANSPORTE

M042

- _Fabricado en acero inoxidable.
- _Estructura reforzada.
- _Respaldo articulado mediante cremallera.
- _Barandillas abatibles.
- _Porta-sueros doble gancho, regulable en altura.
- _4 ruedas Ø125 mm, 2 con freno.
- _Disponibile versión radio-transparente (Mo42-X) máximo tesla 1,5
- _Accesorios: cesta almacenamiento, porta-botellas de oxígeno, bandeja porta-objetos y lecho desmontable (-D).



🇬🇧 STRETCHER Trolley

- _Manufactured in stainless steel.
- _Reinforced frame.
- _Articulated back-rest by ratchet system.
- _Side rails.
- _Serum holder 2 hooks, height adjustable.
- _4 wheels Ø125 mm, 2 with brakes.
- _Available X-ray permeable (Mo42-X).
- _Options: storage basket, oxygen bottle holder, shelf, removable bed (-D).

🇫🇷 Chariot BRANCARD

- _Bâti en acier inoxydable.
- _Structure renforcé.
- _Dossier réglable par crémaillère.
- _Barrières rabattables.
- _Porte Serum 2 crochets, réglable en hauteur.
- _4 roues Ø125 mm, dont 2 avec freins.
- _Disponibile perméable aux rayons X (Mo42-X).
- _Accessoires: panier de rangement, porte-bouteille d'oxygène, étagère, lit amovible (-D).

M042X



M042XD



REF



KG

| | | |
|--------|-----------------|-------|
| M042 | 1950x670x850 mm | 38 kg |
| M042X | 1950x670x850 mm | 38 kg |
| M042XD | 1950x670x850 mm | 38 kg |

Fabricado en acero inox.
Desmontable

carros

trolleys
chariots

transporte cadaver / cadaver / cadavres

transporte / stretcher / brancard

carros porta-cestas / trolleys carrying baskets / portant des paniers

Carro de TRANSPORTE ELEVABLE

M043

- _Estructura robusta, en acero pintado epoxi.
- _Lecho 2 cuerpos de material compacto fenólico.
- _Radio-transparente con colchoneta tapizada desmontable.
- _Respaldo abatible doble cilindro de gas con palanca.
- _Tren y antitren a gas en palanca.
- _Elevación en altura hidráulica en pedal bilateral con descarga.
- _Barandillas laterales abatibles.
- _4 ruedas de Ø150 mm, freno centralizado y rueda direccional.
- _Quinta rueda de Ø125 mm.
- _Asideros de empuje.
- _4 roldanas paragolpes y bandas antirozaduras laterales.
- _2 acoples para portasueros en cabecera.
- _Portasuero telescópico y escamoteable.
- _Base con carenado metálico, portaobjetos y portabotella de oxígeno

Tapizado con resistencia a la abrasión, transpiración, saliva, sangre, orina, luz UV, aceites y manchas. Protección antimicrobiana, antibacteriana y antimicótico. Ignífugo M2 y lavable. Impermeabilidad.



🇬🇧 STRETCHER Trolley

- _Reinforced structure, epoxy painted steel.
- _2 sections, in phenolic compact material.
- _Radio-transparent upholstered mattress.
- _Adjustable backrest, by gas cylinder.
- _Trendelemburg and reverse by gas spring.
- _Height adjustable by hydraulic lift pedal.
- _Side rails.
- _4 wheels Ø150 mm, central braking and steering wheel. Fifth wheel 125 mm.
- _Push handles.
- _4 bumpers.
- _2 fittings for IV pole.

High density foam mattress, resistance to abrasion, saliva, blood, urine, UV light, oils and stains. Antimicrobial protection, antibacterial and antifungal. Fireproof M2 and washable. Waterproof.



🇫🇷 Chariot BRANCARD

- _Structure renforcée, peinture époxy acier.
- _2 sections, en matériau compact phénolique.
- _Radio-transparent, avec matelas amovible rembourrée.
- _Dossier réglable, à gaz.
- _Trendelemburg et arrière par le ressort à gaz.
- _Hauteur réglable par pédale de levage hydraulique.
- _Rails latéraux.
- _4 roues Ø150 mm, freinage central. Sellette 125 mm.
- _Poignées de poussée.
- _4 butoirs.
- _2 raccords pour la potence.

Matresss avec mousse à haute densité, résistance à l'abrasion, salive, sang, urine, UV, huiles et les taches. Protection antimicrobienne, antibactérienne et antifongique. Ignifuge M2 et lavable. Imperméable à l'eau.



REF



KG

M043

1880x700x610-970 mm

97 kg

carros

cestas
iso

transporte cadaver / cadaver / cadavres

transporte / stretcher / brancard

carros porta-cestas / trolleys carrying baskets / portant des paniers

Carros CESTAS ISO

- _Encimera de trabajo en ABS con reborde 3 lados.
- _Estructura en acero inoxidable con guías para cestas.
- _Varios modelos con diferentes capacidades para cestas pequeñas, medianas y grandes.
- _Empujadores laterales.
- _Ruedas giratorias de Ø125 mm, 2 con freno.
- _Opcional: Estante de apoyo en acero inoxidable en la parte inferior.
- _Se pueden colocar algunos accesorios de carros.

🇬🇧 ISO BASKETS Trolleys

- _Worktop in ABS with 3 rims.
- _Structure made in stainless steel with guides for baskets.
- _There are several models with different capacities for little, medium or large baskets.
- _Lateral push handle.
- _Optional: shelf in stainless steel in the lower part.
- _4 wheel of Ø125 mm, 2 with brakes.
- _Supports trolleys accessories.

🇫🇷 Chariots PANIERS ISO

- _Plan de travail en ABS avec 3 bords.
- _Structure en acier inoxydable avec des guides pour paniers.
- _Plusieurs modèls avec des différents capacités pour des paniers petits, moyens et grands.
- _Poignée latéral.
- _4 roues de Ø125 mm, 2 avec des freins.
- _Soutient accessoires chariots.

M8005



M8003



M8005



M8009

REF



| | | |
|-------|-----------------|--------------|
| M8003 | 670x430x750 mm | Cuatro guías |
| M8005 | 670x430x950 mm | Cinco guías |
| M8009 | 670x430x1700 mm | Nueve guías |



pediatría

pediatric

pédiatrique

Cuna PRESALIDA

- _Fabricada en acero inoxidable.
- _Cestillo de metacrilato transparente con orificios de ventilación desmontable.
- _Ruedas Ø80 mm con paragolpes, 2 con freno.
- _Accesorios disponibles: colchón (M034-H), bandeja inferior (M034-B), armario (M034-R).

NEW-BORNS Cradle

- _Stainless steel structure.
- _Crib made of transparent methacrylate with ventilation holes, removable.
- _Wheels Ø80 mm with bumpers, 2 with brakes.
- _Accessories: mattress (M034-H), lower shelf (M034-B), and cupboard (M034-R).

Berceau NOUVEAU-NÉ

- _Structure fabriquée en acier inoxydable.
- _Coque en plexiglas transparent avec orifices d'aération, amovible.
- _Roulettes Ø80 mm avec pare-chocs, 2 à frein.
- _Accessoires: matelas (M034-H), étagère inférieure (M034-B), et armoire (M034-R).

M034A+
M034-H



M034A+
M034-B

M034A+
M034-R



REF



KG

| | | | |
|--------|----------------|--------|---------|
| M034A | 760x450x870 mm | 14 kg | Cuna |
| M034-B | 750x450x30 mm | 1,5 kg | Bandeja |
| M034-H | 38x67x5 mm | | Colchón |

Cuna PEDIÁTRICA

- _Fabricada en acero inoxidable. Frontales y laterales con protección de metacrilato.
- _Cabecero y piecero articulado con barandillas abatibles.
- _Gotero en acero inoxidable, con 2 ganchos, regulable en altura.
- _Ruedas Ø80 mm con paragolpes, 2 con freno.
- _Accesorios disponibles: colchón (M034-HC).

PEDIATRIC Baby Cradle

- _Stainless steel structure. Four sides with transparent methacrylate protection.
- _Articulated head-rest and foot-rest with folding rails.
- _Serum holder, two hooks.
- _Wheels Ø100 mm with bumpers, 2 with brakes.
- _Accessories: mattress (M034-HC).

Berceau NOUVEAU-NÉ

- _Structure fabriquée en acier inoxydable. 4 côtes avec protection en plexiglas transparent.
- _Appui-tête et repose-pieds réglable avec barrières de protection réglables.
- _Tige porte sérum à 2 crochets.
- _Roulettes Ø80 mm avec pare-chocs, 2 à frein.
- _Accessoires: matelas (M034-HC).

M034CO



REF



KG

| | | | |
|---------|------------------|-------|---------|
| M034CO | 1100x550x1380 mm | 15 kg | Cuna |
| M034-HC | 1030x530x50 mm | | Colchón |

Pesabebés ELECTRÓNICO

M214-BN

- _Fabricado en ABS antideslizante, diseño ergonómico.
- _Pantalla LCD de facil lectura.
- _Función TARA y HOLD automático. Apagado automático.
- _Seleccionable KGS/Lbs.
- _Opera mediante pila (no incluida).
- _Como accesorio puede incluirse tallímetro infantil.



🇬🇧 ELECTRONIC Babyscale

- _Easy to use baby and toddler scale for the checkup of babies' weight at the GPs office and at home.
- _Perfectly suitable for the rent out service at pharmacies.
- _Quickly operated by clear push buttons.
- _Functions: Tare, auto-hold, unit switch kg/lbs, automatic zero setting, low battery indication and breast milk input calculator.
- _LCD Screen.
- _Powered by batteries (not included).

🇫🇷 Pèse-bébés ELECTRONIC

- _Fabriqué en ABS antidérapante, design ergonomique.
- _Plateau amovible.
- _Fonction tares, hold, indicateur de niveau de batterie faible, mise à zero automatique.
- _Selectionable KGS/Lbs.
- _Alimenté par pile (ne pas ninclus).

Especificaciones técnicas:
- Capacidad: 20 kg
- Sensibilidad: 5 gr
- Bandeja: 600x280x40 mm

Technical specifications:
Capacity: 20 kg
Sensibility: 5 gr
Tray: 600x280x40 mm.

Caractéristiques techniques:
Capacité: 20 kg
Sensibilité: 5 gr
Plateau: 600x280x40 mm



M214-BN

560x350x130 mm

5 kg

Pesabebés ELECTRÓNICO CLASE III

M214-CE

- _Báscula electrónica pesa bebés y para niños pequeños de hasta 20kg.
- _Ideal para clínicas y uso hospitalario.
- _Bandeja suave y extraíble de forma curva, proporciona un espacio cómodo para los bebés, permitiendo pesarlos de pie.
- _Pantalla LCD 25mm
- _Funciones: tara, hold, puesta a cero automática e indicación de batería baja. Incluye pilas y adaptador de red.
- _Permite pesar a los niños de pie.



🇬🇧 ELECTRONIC Babyscale CLASS III

- _Electronic babyscale for babies and toddlers up to 20 kg.
- _LCD screen 25 mm.
- _The removable soft curved baby tray gives comfortable space to babies and allows toddlers to be weighed in a standing upposition.
- _Functions: Tare, hold, automatic zero setting, low battery indication.
- _Power supply: batteries and adapter included.
- _Despite allows children standing.

Especificaciones técnicas:
Capacidad: 20 kg
Sensibilidad: 10 gr
Bandeja: 575 x 70x 275 mm

Technical specifications:
Capacity: 20 kg
Sensibility: 10 gr
Tray: 575 x 70x 275 mm

🇫🇷 Pèse-bébés ELECTRONIC CLASSE III

- _Écran en LCD 25 mm.
- _Plateau détachable qui permet de peser aussi bien les nourrissons que les enfants en bas âge (jusqu'à 20 kg).
- _Fonction tares, hold, indicateur de niveau de batterie faible, mise à zero automatique.
- _Alimentation: les batteries et l'adaptateur.
- _Malgré permet aux enfants debout.

Caractéristiques techniques:
Capacité: 20 kg
Sensibilité: 10 gr
Plateau: 575 x 70x 275 mm



M214-CE

575x200x300 mm

18.5 kg

Mesa DESNUDA BEBÉS

- _Fabricado en acero esmaltado (Mo78) o inoxidable (Mo78-I).
- _Estructura soldada de gran solidez.
- _Colchón de gomaespuma de gran densidad, tapizado en polipiel, varios colores a elegir (negro, azul, blanco, celeste, verde...).
- _Estantes interior.
- _Protectores acolchados en tres lados.
- _Patas con topes, una con nivelador.
- _Opciones: ruedas, cajones, tabla auxiliar abatible para colocar pesabebés...

Table to UNDRRESS BABIES

- _Enamelled steel (Mo78) or stainless steel (Mo78-I) structure.
- _Reinforced frame.
- _High density foam padded, upholstered in leatherette, fireproof. Several colours.
- _Padded on three sides.
- _Legs with rubber protection, and one leveling.
- _Options: castors, shelf, drawers, collapsible shelf table to place baby scales...

Table PÉDIATRIQUE

- _Bâti en acier revêtement époxy polyester (Mo78) ou acier inoxydable (Mo78-I).
- _Structure renforcé.
- _Rembourré en mousse haute densité, revêtu en simili-cuir, anti-feu.
- _Plusieurs couleurs.
- _Rembourré sur trois côtés.
- _Pieds avec protection en caoutchouc, et 1 patin réglable
- _Options: roulettes, étagère, tiroirs, plateau pliable pour placer les pèse-bés...

M078-I



M078-IC2



Opción: cajones.
Option: drawers.
Options: tiroirs.



M078



1200x550X950 mm



15 kg

Cambiador de PARED

- _Diseño ergonómico y seguro, plegable para ahorrar espacio, se puede abrir y cerrar con una sola mano.
- _Fabricado en polietileno, color beige, antibacteriano y fácil de limpiar.
- _Reforzado longitudinalmente con mecanismo de bisagra de acero cilíndrica y accionamiento neumático.
- _Correa de seguridad, ajustable.
- _Modelo horizontal o vertical.

Baby CHANGING TABLE

- _Ergonomic and safety design, foldable to save space, can be opened and closed with one hand.
- _Made of polyethylene, beige colour, antimicrobial and easy to clean.
- _Reinforcements with hinges cylindrical of steel and pneumatic action.
- _Adjustable safety belt.
- _Model horizontal or vertical.

Table à LANGER

- _Design sûr et ergonomique, pliable, elle s'ouvre et se ferme d'une seule main en toute sécurité.
- _Fabriqué en polyéthylène, de couleur beige, antibactériennes et facilement lavable.
- _Renforts avec charnières cylindrical of acier et l'action pneumatique.
- _Ceinture de sécurité réglable.
- _Modèle horizontale ou verticale.

M7818H-EC



M7818V-EC



M7818H-EC



510x880x 500 mm



11 kg

M7818V-EC

905x575x145 mm

11 kg

Cambiador de PARED

_Diseño ergonómico y seguro, plegable para ahorrar espacio, se puede abrir y cerrar con una sola mano.

_Fabricado en ABS, color gris, antibacteriano y fácil de limpiar.

_Estante para accesorios integrado y 2 ganchos a ambos lados para colgar el bolso o la bolsa de pañales sin poner en peligro la seguridad del niño.

_Correa de seguridad, ajustable.

_Modelo horizontal o vertical.

🇬🇧 Baby CHANGING TABLE

_Ergonomic and safety design, foldable to save space, can be opened and closed with one hand.

_Made of ABS, gray colour, antimicrobial and easy to clean.

_Built-in accessory shelf and 2 hooks on both sides to hang bag.

_Adjustable safety belt.

_Model horizontal or vertical.

🇫🇷 Table à LANGER

_Design sûr et ergonomique, pliable, elle s'ouvre et se ferme d'une seule main en toute sécurité.

_Fabriqué en polypropylène, de couleur grise, antibactériennes et facilement lavable.

_Elle possède des crochets en aluminium qui permettent d'accrocher un sac ainsi qu'une étagère intégrée pour stocker la poudre pour bébés et autres articles peu volumineux.

_Ceinture de sécurité réglable.

_Modèle horizontale ou verticale.



M7818-H



M7818-V



| REF | Dimensions (mm) | Weight (kg) |
|---------|-----------------|-------------|
| M7818-H | 862x557x120 mm | 15 kg |
| M7818-V | 595x978x120 mm | 15 kg |

Mesa Exploración PEDIÁTRICA

_Estructura en acero esmaltado (M160) o acero inoxidable (M161).

_Estructura soldada de gran solidez.

_Gomaespuma de gran densidad, tapizado en polipiel

_Varios colores a elegir.

_Cabecero articulado mediante cremallera.

_Patas con protectores, una con nivelador.

🇬🇧 Paediatric EXAMINATION COUCH

_Framework made of epoxy powder coated steel (M160), or stainless steel (M161). Reinforced frame.

_High density foam padded, upholstered in leatherette.

_Several colours. Articulated back-rest by ratchet system.

_Legs with rubber protection, and one leveling.

🇫🇷 Table d'examen PÉDIATRIQUE

_Bâti en acier revêtement époxy polyester (M160) ou acier inoxydable (M161). Structure renforcé.

_Pieds avec protection en caoutchouc, et 1 patin réglable.

_Rembourré en mousse haute densité, revêtu en simili-cuir.

_Plusieurs couleurs.

_Dossier réglable par crémaillère.



M161



| REF | Dimensions (mm) | Weight (kg) | Material |
|------|-----------------|-------------|-------------|
| M160 | 1500x500x800 mm | 17 kg | Esmaltado |
| M161 | 1500x500x800 mm | 16 kg | Acero inox. |



mesas

tables

Mesa auxiliar BÁSICA

M098

- _Fabricada en acero esmaltado (M093) o acero inoxidable (M098).
- _2 estantes lisos en acero inoxidable.
- _4 ruedas Ø80 mm, 2 con freno.
- _El modelo M098 está disponible también con 3 estantes (M098-3)

BASIC Auxiliary Table

- _Framework made of epoxy powder coated steel (M093), or stainless steel (M098).
- _2 smooth shelves in stainless steel.
- _Wheels Ø80mm, 2 with brakes.
- _Model M098 available with 3 shelves (M098-3)

Table auxiliar BASIQUE

- _Bâti en acier revêtement époxy polyester (M093) ou acier inoxydable (M098).
- _2 étagères lisses.
- _Roulettes Ø80 mm, dont 2 à frein.
- _Le modèle M098 est disponible avec 3 étagères (M098-3).



REF

↔ ↙ ↕

KG

Acabado

| | | | |
|--------|----------------|-------|-------------|
| M093 | 600x400x800 mm | 8 kg | Esmaltado |
| M098 | 600x400x800 mm | 9 kg | Acero inox. |
| M098-3 | 600x400x800 mm | 11 kg | Acero inox. |

Mesa auxiliar CON BARANDILLAS

M091

- _Fabricada en acero esmaltado (M092) o inoxidable (M091).
- _2 estantes lisos en acero inoxidable.
- _Estante superior con barandilla.
- _4 ruedas Ø80 mm, 2 con freno.

Auxiliary Table WITH RAILING

- _Framework made of epoxy powder coated steel (M092) or stainless steel (M091).
- _2 smooth shelves in stainless steel.
- _Upper shelf with 3 rims.
- _Wheels Ø80 mm, 2 with brakes.

Table auxiliar AVEC GALERIE

- _Bâti en acier revêtement époxy polyester (M092) ou acier inoxydable (M091).
- _2 étagères lisses.
- _Étagère supérieure avec galerie.
- _Roulettes Ø80 mm, dont 2 à frein.



REF

↔ ↙ ↕

KG

Acabado

| | | | |
|------|----------------|-------|-------------|
| M091 | 600x400x850 mm | 9 kg | Acero inox. |
| M092 | 600x400x850 mm | 10 kg | Esmaltado |

Mesa auxiliar CON CAJÓN

- _Estructura fabricada en acero esmaltado (Mog4) o inoxidable (Mog5).
- _1 o 2 cajones.
- _2 estantes lisos en acero inoxidable. Estante superior con barandilla.
- _4 ruedas Ø80mm, 2 con freno.
- _Modelo Mog5-2 solo en acero inoxidable.

🇬🇧 Auxiliary Table WITH DRAWER

- _Framework made of epoxy powder coated steel (Mog4) or stainless steel (Mog5). 1 or 2 drawers.
- _2 smooth shelves in stainless steel.
- _Upper shelf with 3 rims.
- _Wheels Ø80mm, 2 with brakes.
- _Model Mog5-2 only in stainless steel.

🇫🇷 Table auxiliar AVEC TIROIR

- _Bâti en acier revêtement époxy polyester (Mog4) ou acier inoxydable (Mog5). 1 ou 2 tiroirs.
- _2 étagères lisses.
- _Étagère supérieure avec galerie.
- _Roulettes Ø80mm, dont 2 à frein.
- _Modèle Mog5-2 seulement en acier inoxydable.



M095



M095-2



Acabado

| REF | Dimensions | KG | Acabado |
|--------|----------------|-------|-------------|
| M094 | 600x400x850 mm | 15 kg | Esmaltado |
| M095 | 600x400x850 mm | 14 kg | Acero inox. |
| M095-2 | 600x400x850 mm | 14 kg | Acero inox. |

Mesa auxiliar con BANDEJA

- _Estructura fabricada en acero inoxidable.
- _2 bandejas desmontables (Mog6).
- _Disponible modelo con bandeja superior y estante inferior fijo (Mog7).
- _4 ruedas Ø80 mm, 2 con freno.

🇬🇧 Auxiliary table with TRAY

- _Framework made of stainless steel.
- _2 removable trays in stainless steel (Mog6).
- _Available model with upper tray and lower shelf (Mog7).
- _Wheels Ø80 mm, 2 with brakes.

🇫🇷 Table auxiliar avec PLATEAU

- _Bâti en acier inoxydable.
- _2 plateaux démontables (Mog6).
- _Disponible modèle avec panneau et étagère (Mog7).
- _Roulettes Ø80 mm, dont 2 à frein.



M096

M097



Acabado

| REF | Dimensions | KG | Acabado |
|------|----------------|------|-------------|
| M096 | 600x400x800 mm | 9 kg | Acero inox. |
| M097 | 600x400x800 mm | 9 kg | Acero inox. |

Mesa auxiliar FENÓLICA

- _Estructura fabricada en acero inoxidable.
- _Estante en resina fenólica.
- _Disponibile con 2 ó 3 estantes.
- _Consulte por otras medidas y colores.
- _4 ruedas Ø70 mm, 2 con freno.

🇬🇧 PHENOLIC auxiliary Table

- _Framework made of stainless steel.
- _Shelf in phenolic resin.
- _2 or 3 shelves.
- _Consult for other measures and colours.
- _Wheels Ø70 mm, 2 with brakes.

🇫🇷 Table auxiliar PHÉNOLIQUE

- _Bâti en acier inoxydable.
- _2 ou 3 étagères en résine compacte.
- _Consultez par autres mesures et couleurs.
- _Roulettes Ø70 mm, dont 2 à frein.

M098-3E-F



M098-2E-F



REF



KG

| | | |
|-----------|----------------|-------|
| M098-2E-F | 600x400x850 mm | 10 kg |
| M098-3E-F | 600x400x850 mm | 12 kg |

Mesa auxiliar FENÓLICA

- _Estructura fabricada en acero inoxidable.
- _Estante en resina fenólica con barandilla en acero inoxidable.
- _Disponibile con 2 ó 3 estantes.
- _Consulte por otras medidas y colores.
- _4 ruedas Ø70 mm, 2 con freno.

🇬🇧 PHENOLIC auxiliary Table

- _Framework made of stainless steel.
- _Shelves in phenolic resin.
- _2 or 3 shelves with rims.
- _Consult for other measures and colours.
- _Wheels Ø70mm, 2 with brakes.

🇫🇷 Table auxiliar PHÉNOLIQUE

- _Bâti en acier inoxydable.
- _Plateaux en résine compacte avec galerie.
- _2 ou 3 étagères.
- _Consultez par autres mesures et couleurs.
- _Roulettes Ø70 mm, dont 2 à frein.

M098-3E-FB



M098-2E-FB



REF



KG

| | | |
|------------|----------------|-------|
| M098-2E-FB | 600x400x850 mm | 10 kg |
| M098-3E-FB | 600x400x850 mm | 12 kg |

Mesa auxiliar CON REBORDES

- _Estructura fabricada en acero inoxidable .
- _2 (M098-2B) o 3 (M098-3B) estantes con rebordes.
- _2 asideros laterales.
- _4 ruedas Ø80 mm, 2 con freno.

🇬🇧 Auxiliary table

- _Framework made stainless steel.
- _2 (M098-2B) or 3 (M098-3B) shelves with rims.
- _Handles on both sides.
- _Wheels Ø80 mm, 2 with brakes.

🇫🇷 Table auxiliar

- _Bâti en acier inoxydable.
- _2 (M098-2B) ou 3 (M098-3B) étagères avec bords relevés.
- _Poignées sur les 2 côtés.
- _Roulettes Ø80 mm, dont 2 à frein.

M098-3B



M098-2B



| | | |
|---------|----------------|-------|
| M098-2B | 600x400x850 mm | 10 kg |
| M098-3B | 600x400x850 mm | 12 kg |

Mesa auxiliar

- _Estructura fabricada en acero inoxidable.
- _2 (M098-2E) o 3 (M098-3E) estantes lisos.
- _2 asideros laterales.
- _4 ruedas Ø80 mm, 2 con freno.

🇬🇧 Auxiliary table

- _Framework made stainless steel.
- _2 (M098-2E) or 3 (M098-3E) smooth shelves.
- _Handles on both sides.
- _Wheels Ø80 mm, 2 with brakes.

🇫🇷 Table auxiliar

- _Bâti en acier inoxydable.
- _2 (M098-2E) ou 3 (M098-3E) étagères lisses.
- _Poignées sur les 2 côtés.
- _Roulettes Ø80 mm, dont 2 à frein.

M098-3E



M098-2E



| | | |
|---------|----------------|-------|
| M098-2E | 600x400x850 mm | 10 kg |
| M098-3E | 600x400x850 mm | 12 kg |

Mesa auxiliar ANESTESIA

M087

- _Fabricada en acero inoxidable.
- _1 o 2 cajones.
- _Bandeja superior desmontable.
- _Estante inferior fijo.
- _Ruedas Ø80mm, 2 con freno.

Auxiliar table ANESTHESIA

- _Manufactured in stainless steel.
- _1 or 2 drawers.
- _Upper tray, dismountable.
- _Lower smooth shelf.
- _Wheels Ø80mm, 2 with brakes.

Table auxiliar ANESTHÉSIE

- _Fabriquée en acier inoxydable.
- _1 ou 2 tiroirs.
- _Plateau supérieur démontable.
- _Étagère inférieure lisse.
- _Roulettes Ø80mm, 2 à frein.



| | | |
|------|----------------|-------|
| M086 | 600x400x800 mm | 16 kg |
| M087 | 600x400x800 mm | 14 kg |

Mesa INSTRUMENTAL MIXTA

M100

- _Fabricada en acero inoxidable.
- _Bandeja superior desmontable.
- _Estante inferior fijo.
- _4 ruedas Ø80 mm con paragolpes, 2 con freno.

MIXED INSTRUMENTS Table

- _Framework made of stainless steel.
- _Removable upper tray.
- _Lower shelf, fixed.
- _Wheels Ø80 mm with bumpers, 2 with brakes.

Table à INSTRUMENTS MIXTE

- _Fabriquée en acier inoxydable
- _Étagère inférieure lisse.
- _Plateau supérieur démontable.
- _Roulettes Ø80 mm, dont 2 à frein.



| | | |
|------|-----------------|-------|
| M100 | 1000x400x800 mm | 14 kg |
|------|-----------------|-------|

Mesa INSTRUMENTAL

- _Fabricada en acero inoxidable.
- _Estante superior con 3 rebordes
- _Estante inferior liso.
- _4 ruedas Ø80 mm con paragolpes, 2 con freno.
- _Disponible en 3 medidas.

🇬🇧 INSTRUMENTS table

- _Framework made of stainless steel.
- _Fixed shelf, with 3 rims
- _Lower smooth shelf.
- _Wheels Ø80 mm with bumpers, 2 with brakes.
- _Available in 3 sizes.

🇫🇷 Table à INSTRUMENTS

- _Bâti en acier inoxydable.
- _Étagère supérieure avec bords sur 3 côtés.
- _Étagère inférieure lisse.
- _Roulettes Ø80 mm, dont 2 à frein.
- _Disponible en 3 tailles.

M101



| REF | ↔ ↙ ↕ | KG |
|------|-----------------|-------|
| M101 | 1000x500x800 mm | 15 kg |
| M102 | 1200x500x800 mm | 16 kg |
| M103 | 1400x500x800 mm | 17 kg |

Mesa Instrumental

- _Fabricada en acero inoxidable.
- _Estante superior, con 3 rebordes. Esquinas abiertas para evitar suciedad.
- _4 ruedas Ø80 mm con paragolpes, 2 con freno.
- _Disponible en 3 largos.

🇬🇧 Instruments Table

- _Framework made of stainless steel.
- _Upper shelf, with 3 rims. Open corners to avoid dirt.
- _Wheels Ø80 mm with bumpers, 2 with brakes.
- _Available in 3 measurements.

🇫🇷 Table à Instrument

- _Bâti en acier inoxydable.
- _Plateau supérieur avec 3 bords relevés.
- _Roulettes Ø80 mm, dont 2 à frein.
- _Coins ouvertes pour éviter la saleté.
- _Disponible 3 measurements.

M101-B



| REF | ↔ ↙ ↕ | KG |
|--------|-----------------|-------|
| M101-B | 1000x500x800 mm | 14 kg |
| M102-B | 1200x500x800 mm | 15 kg |
| M113-B | 1400x500x800 mm | 16 kg |

Mesa INSTRUMENTAL RIÑÓN

M110

- _Fabricada en acero inoxidable.
- _Estante superior con 3 rebordes
- _4 ruedas Ø80 mm con paragolpes, 2 con freno.
- _Disponible en 3 largos.

Table KIDNEY SHAPE

- _Framework made of stainless steel.
- _Upper shelf, with 3 rims
- _Wheels Ø80 mm with bumpers, 2 with brakes.
- _3 available measurements.

Table à INSTRUMENTS REIN

- _Bâti en acier inoxydable.
- _Plateau supérieur avec 3 bords rèles.
- _Roulettes Ø80 mm, dont 2 à frein.
- _Disponible 3 measurements.



| REF | Dimensions (mm) | Weight (kg) |
|------|-----------------|-------------|
| M110 | 1000x500x800 mm | 14 kg |
| M111 | 1200x500x800 mm | 15 kg |
| M112 | 1400x500x800 mm | 16 kg |

Mesa Instrumental "CURVA"

M110-B

- _Fabricada en acero inoxidable.
- _Estante superior reforzado, con 3 rebordes. Esquinas abiertas para evitar suciedad.
- _Parte delantera curva. Parte trasera recta.
- _4 ruedas Ø80 mm con paragolpes, 2 con freno.
- _Disponible en 3 largos.

Instrumentas CURVED Table

- _Framework made of stainless steel.
- _Upper shelf, with 3 rims. Open corners to avoid dirt.
- _Wheels Ø80 mm with bumpers, 2 with brakes.
- _3 available measurements.

Table à Instrument COURBÉ

- _Bâti en acier inoxydable.
- _Coins ouvertes pour éviter la saleté.
- _Plateau supérieur avec 3 bords rèles.
- _Roulettes Ø80 mm, dont 2 à frein.
- _Disponible 3 measurements.



| REF | Dimensions (mm) | Weight (kg) |
|--------|-----------------|-------------|
| M110-B | 1000x500x800 mm | 14 kg |
| M111-B | 1200x500x800 mm | 15 kg |
| M112-B | 1400x500x800 mm | 16 kg |

Mesa MAYO

- _Fabricada en acero inoxidable.
- _Regulable en altura manualmente.
- _Bandeja desmontable 600x400x20 mm
- _Ruedas Ø80 mm, 2 con freno.
- _Varios modelos.

🇬🇧 MAYO Table

- _Framework made of stainless steel.
- _Height adjustable, manually.
- _Removable tray 600x400x20 mm.
- _Wheels Ø80 mm, 2 with brakes.
- _Several models.

🇫🇷 Table à instruments MAY

- _Bâti en acier inoxydable.
- _Réglable en hauteur, manuellement.
- _Plateau démontable 600x400x20 mm.
- _Roulettes Ø80 mm, dont 2 à frein.
- _Divers modèles.

M105-B

M105-C

M105



REF



KG

| | | |
|--------|---------------------|------|
| M105 | 600x400x900-1250 mm | 7 kg |
| M105-B | 600x400x900-1250 mm | 7 kg |
| M105-C | 600x400x900-1250 mm | 7 kg |

Mesa MAYO ANTIGIRO

M105-A

- _Fabricada en acero inoxidable.
- _Regulable en altura manualmente.
- _Bandeja desmontable 600x400x20 mm.
- _4 ruedas Ø80 mm, 2 con freno.

🇬🇧 MAYO Table NON-ROTATING

- _Framework made of stainless steel.
- _Height adjustable, manually.
- _Removable tray 600x400x20 mm.
- _Wheels Ø80 mm, 2 with brakes.

🇫🇷 Table à instruments MAYO ANTI-ROTATION

- _Bâti en acier inoxydable.
- _Réglable en hauteur, manuellement.
- _Plateau démontable 600x400x20 mm.
- _Roulettes Ø80 mm, dont 2 à frein.



REF



KG

| | | |
|--------|---------------------|------|
| M105-A | 600x400x900-1250 mm | 7 kg |
|--------|---------------------|------|

Mesa MAYO HIDRÁULICA

M105-H

- _Fabricada en acero inoxidable.
- _Regulable en altura por pistón hidráulico.
- _Bandeja desmontable (650x530x35 mm).
- _Base con 4 ruedas, 2 con frenos.

🇬🇧 HYDRAULIC MAYO table

- _Framework made of stainless steel.
- _Hydraulic height adjustable, by foot pedal.
- _Removable tray.
- _4 wheels, two with brakes.

🇫🇷 Table à instruments MAYO HYDRAULIQUE

- _Bâti en acier inoxydable.
- _Réglable en hauteur, hydraulique.
- _Plateau démontable.
- _4 roulettes, avez des freins.



| REF | Dimensions | KG |
|--------|---------------------|------|
| M105-H | 680x450x950-1250 mm | 7 kg |

Mesa instrumental CAMPO

M106

- _Fabricada en acero inoxidable.
- _Encimera fija, con 4 rebordes o sin rebordes (-B).
- _Regulable en altura.
- _2 ruedas Ø80mm. Opción 4 ruedas, 2 con freno (-R).

🇬🇧 Instruments table CAMPO

- _Framework made of stainless steel.
- _Upper fixed tray, with 4 rims or without rims (-B)
- _2 wheels Ø80 mm. Option 4 wheels, 2 with brakes (-R).

🇫🇷 Table à instruments CAMPO

- _Bâti en acier inoxydable.
- _Plateau supérieur fixe, avec 4 bords rèles ou sans bords (-B)
- _2 roulettes Ø80mm. Option 4 roulettes, dont 2 à frein.

M106-B



| REF | Dimensions | KG |
|----------|----------------------|-------|
| M106 | 1000x500x900-1400 mm | 12 kg |
| M106-R | 1000x500x900-1400 mm | 12 kg |
| M106-B | 1000x500x900-1400 mm | 12 kg |
| M106-B-R | 1000x500x900-1400 mm | 12 kg |

Mesa TOMA DE MUESTRAS

- _Estructura en acero esmaltado (Mo82) o inoxidable (Mo82-I).
- _Estante en acero inoxidable.
- _Apoyabrazos en acero inoxidable o tapizado (T), posibilidad de colocar a izquierda o derecha.
- _Soporte para cubo de restos.

🇬🇧 BLOOD SAMPLING Table

- _Framework made of enamelled (Mo82) or stainless steel (Mo82-I).
- _Worktop in stainless steel.
- _Arm-holder in stainless steel or upholstered (-T).
- _Support for bucket.

🇫🇷 Table de PRÉLÈVEMENT

- _Bâti en acier revêtement époxy polyester (Mo82) ou acier inoxydable (Mo82-I).
- _Plateau en acier inoxydable.
- _Support de bras en acier inoxydable ou recouvert (-T).
- _Support pour poubelle.

M082-T



M082-I



Acabado

Soporte de brazo

| REF | Dimensions (mm) | KG | Acabado | Soporte de brazo |
|----------|-----------------|-------|-------------|------------------|
| M082 | 600x400x850 mm | 8 kg | Esmaltado | Acero inox. |
| M082-T | 600x400x850 mm | 8 kg | Esmaltado | Tapizado |
| M082-I | 600x400x850 mm | 10 kg | Acero inox. | Acero inox. |
| M082-I-T | 600x400x850 mm | 10 kg | Acero inox. | Tapizado |

Mesa TOMA DE MUESTRAS

- _Estructura en acero esmaltado.
- _Superficie tapizada.
- _Disponible modelo doble (Mo89-2) y triple (Mo89-3) con separadores.

🇬🇧 BLOOD SAMPLING Table

- _Framework made of enamelled steel.
- _Worktop upholstered
- _Available double (Mo89-2) and triple (Mo89-3) models, with separation.

🇫🇷 Table de PRÉLÈVEMENT

- _Bâti en acier revêtement époxy polyester.
- _Plateau recouvert.
- _Disponibles modèles doubles (Mo89-2) et triples (Mo89-3) avec séparateurs.

M089



| REF | Dimensions (mm) | KG | Configuration |
|--------|-----------------|-------|---------------|
| M089 | 600x400x850 mm | 8 kg | Simple |
| M089-2 | 1200x400x850 mm | 16 kg | Doble |
| M089-3 | 1800x400x850 mm | 25 kg | Triple |

Mesa VETERINARIA

M5001

- _Fabricada en acero inoxidable.
- _Regulable en altura manualmente.
- _Estante superior liso con canal y orificio de drenaje.
- _Incluye bandeja para instrumental y portasueros.

🇬🇧 VETERINARY Table

- _Framework made of stainless steel.
- _Height adjustable, manually.
- _Tray for instruments and IV pole.
- _Shelf with canal and drain hole.

🇫🇷 Table VETERINAIRE

- _Bâti en acier inoxydable.
- _Réglable en hauteur, manuellement.
- _Plateau pour instruments et porte sèrum.
- _Étagère supérieure avec canal et orifice de drainage.



M5001

1200x600x800-1300 mm

20 kg

Mesa DISECCIÓN

M199

- _Fabricada en acero inoxidable.
- _Bandeja para instrumental. Soporte corredero.
- _4 ruedas Ø125 mm, 2 con freno.
- _Estante superior con canal y orificio de drenaje.

🇬🇧 DISSECTION Table

- _Framework made of stainless steel.
- _Tray for instrumentals. Sliding support.
- _Wheels Ø125 mm.
- _Shelf with canal and drain hole.

🇫🇷 Table de DISSECTION

- _Bâti en acier inoxydable. Plateau pour instruments. Support coulissant.
- _Roulettes Ø125 mm, dont 2 à frein.
- _Étagère supérieure avec canal et orifice de drainage.

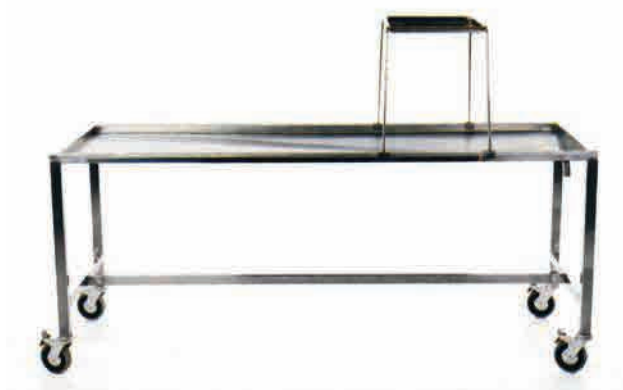

M199

2100x600x850 mm

30 kg

Mesa instrumental L

M113

- _Fabricada en acero inoxidable.
- _Estante superior reforzado, con rebordes laterales.
- _Ruedas Ø80 mm con paragolpes, 3 con freno.

🇬🇧 Instrument tables L

- _Framework made of stainless steel.
- _Reinforced upper shelf, with lateral rims
- _Wheels Ø80 mm with bumpers, 3 with brakes.

🇫🇷 Table à instruments L

- _Bâti en acier inoxydable.
- _Plateau supérieur fixe, avec bords laterales relevés.
- _Roulettes Ø80 mm, dont 3 à frein.



M113



1400x500x800 mm
(L) 900x500x800 mm



25 kg

Mesa de CAMA ATRIL

M181

- _Estructura en acero inoxidable.
- _Atril en fenólico, orientable.
- _Regulable en altura manualmente, 85-120cm.
- _Ruedas Ø40 mm.

🇬🇧 BED Table

- _Framework made of stainless steel.
- _Phenilic resin surface.
- _Adjustable in height, manually, 85-120 cm.
- _Wheels Ø40 mm

🇫🇷 Table de LIT

- _Bâti en acier inoxydable.
- _Plateau en phénolique.
- _Hauteur réglable manuellement, 85-120 cm.
- _Roulettes Ø40 mm.



M181



600x400-850x1200 mm



8 kg

Mesas de CAMA ATRIL con reborde

M181-M1

- _Estructura en acero esmaltado basculante 90°.
- _Atril en melamina, orientable, esquinas redondeadas.
- _Regulable en altura manualmente, 70-110cm.
- _4 ruedas giratorias.

BED table with rims

- _Framework made of epoxy powder coated steel.
- _Melamine surface with rims.
- _Adjustable in height, manually, 70-110 cm.
- _4 rolling wheels.

Table de LIT avec bords relevés

- _Bâti en acier revêtement époxy polyester.
- _Plateau en melamine avec bord relevés.
- _Hauteur réglable manuellement, 70-110 cm.
- _4 roulettes.



M181-M1

600x380x700-1100 mm

Mesas de CAMA ATRIL con reborde

M181-M2

- _Estructura en acero esmaltado.
- _Atril en MDF, orientable con bordes (90°).
- _Regulable en altura manualmente, 70-120cm.
- _4 ruedas giratorias.

BED table with rims

- _Framework made of epoxy powder coated steel.
- _MDF surface with rims (90°).
- _Adjustable in height, manually, 70-120 cm.
- _4 rolling wheels.

Table de LIT avec bords relevés

- _Bâti en acier revêtement époxy polyester.
- _Plateau en MDF avec bord relevés (90°).
- _Hauteur réglable manuellement, 70-120 cm.
- _4 roulettes.



M181-M2

600x380x700-1200 mm



camillas

examination table

table d'examen

Camilla reconocimiento ELÉCTRICA 2 secciones

M167

- _ Camilla de 2 secciones.
- _ Estructura en tubo de acero esmaltado epoxi.
- _ Regulación de altura mediante motor eléctrico con mando de mano. Respaldo reclinable mediante palancas.
- _ Cabezal con orificio facial. Portarrollos opcional
- _ Nivelador ajustable para evitar los pequeños desniveles.
- _ Disponible modelo regulación altura hidraulico (-H).
- _ Peso soportado 200 kg.

Polipiel: ignífugo de categoría M2, antibacteriano, antimoho, antiséptico, antirayos UV, retardante de llama, impermeable, resistente a la transpiración, a la orina, la sangre y a la saliva humana.



🇬🇧 ELECTRIC examination couch, 2 sections

- _ 2 sections couch with electric height adjustment.
- _ Epoxy-powder coated steel tube frame.
- _ Electric height elevation, hand operated. Mechanical adjustment of head section. Head section with breathing hole.
- _ Adjustable foot for stability. Paper roll holder optional.
- _ Available model with Hydraulic elevation (-H).

Leatherette: Fireproof M2, antimicrobial, antibacterial and antimycotic protection, urine and blood protection, UV light resistance, flame retardant, impermeability.

🇫🇷 Table d'examen ELECTRIQUE électrique, 2 panneaux

- _ Divan de 2 sections.
- _ Structure en tube d'acier peint époxy.
- _ Réglage de la hauteur par moteur électrique avec commande manuelle. Dossier réglable par manivelle. Avec orifice facial.
- _ Niveleur ajustable. Porte-rouleaux optionnel.
- _ Disponible réglage de la hauteur par moteur hydraulique (-H).

Similicuir: classement au feu M2, protection antimicrobienne, antibactérienne et antifongique; résistance à la transpiration, la salive humaine, l'urine et au sang; résistance à la lumière UV, Impermeabilité.

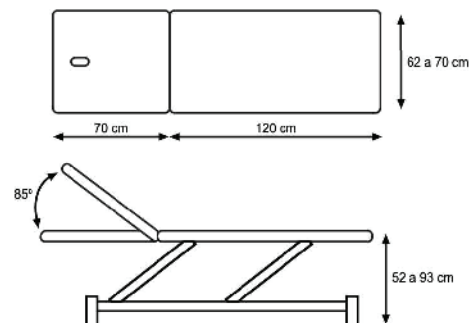

ACCESORIOS / ACCESSORIES / ACCESSOIRES



Reposabrazos tapizado.

Upholstered armrest
Accoudoirs tapisés



Portarrollos.

Paper-roll holder
Porte-rouleau

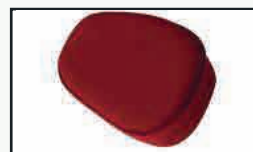

Tapón facial

Breathing hole plug
Bouchon facial



Barandillas

Side rails
Barrières de sécurité



M167

1900x620x520-930 mm

camillas

examination tables
tables d'examination

de reconocimiento / examination couch / table d'examen
ginecológica / gynaecology / gynécologique
camilla obesos / examination table obese / table d'examination obèses

Camilla RECONOCIMIENTO ELÉCTRICA, 2 secciones, con ruedas

M169

- _Estructura en tubo de acero esmaltado epoxi.
- _Regulación de altura mediante motor eléctrico con mando de mano.
- _Respaldo reclinable mediante palancas. Cabezal con orificio facial.
- _Nivelador ajustable para evitar los pequeños desniveles.
- _Sistema de ruedas escamoteables mediante pedales.
- _Disponibile modelo altura hidraulico (-H).
- _Peso soportado 200 kg.

Polipiel: ignífugo de categoría M2, antibacte-riano, antimoho, antisalínico, antirayos UV, retardante de llama, impermeable, resistente a la transpiración, a la orina, la sangre y a la saliva humana.

ELECTRIC examination couch, 2 sections with wheels

- _Epoxy-powder coated steel tube frame.
- _Electric height elevation, hand operated.
- _Mechanical adjustment of head section. Head section with breathing hole. Adjustable foot for stability. Base with retractable castors, pedal operated.
- _Available model with Hydraulic elevation (-H).

Leatherette: Fireproof M2, antimicrobial, antibacterial and antimycotic protection, urine and blood protection, UV light resistance, flame retardant, impermeability.

Table d'examen ELECTRIQUE, 2 sections, avec roues

- _Structure en tube d'acier peint époxy.
- _Réglage de la hauteur par moteur électrique avec commande manuelle. Dossier réglable par manivelle. Avec orifice facial.
- _Niveleur ajustable.
- _Système de roues rétractables par des pédales.
- _Disponibile réglage de la hauteur par moteur hydraulique.

Similicuir: classement au feu M2, protection antimicrobienne, antibacterienne et antifongique; resistance à la transpiration, la salive humaine, l'urine et au sang; resistance à la lumière UV, Impermeabilité

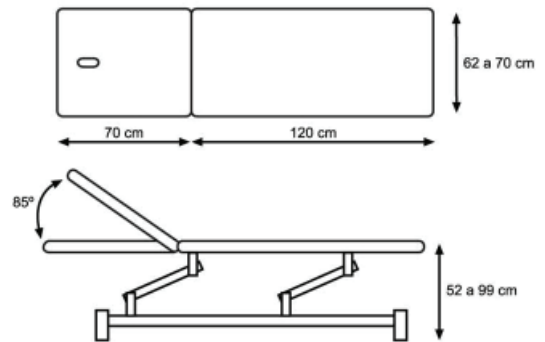

ACCESORIOS / ACCESSORIES / ACCESSOIRES



Portarrollos
Paper roll holder
Porte-rouleaux



Reposabrazos plano tapizado
Upholstered Armrest
Accoudoirs tapisés



Tapón facial
Breathing hole plug
Bouchon facial



Periférico
Perimeter foot switch
Périferique



M169

1900x620-700x520-930 mm

camillas

examination tables
tables d'examination

de reconocimiento / examination couch / table d'examen
ginecológica / gynaecology / gynecologique
camilla obesos / examination table obese / table d'examination obèses

Camilla reconocimiento ELÉCTRICA 3 secciones

M150

- _Camilla de 3 secciones con regulación de altura.
- _Estructura en tubo de acero esmaltado epoxi.
- _Regulación de altura mediante motor eléctrico con mando de mano.
- _Respaldo reclinable mediante palancas.
- _Piecera reclinable mediante palancas.
- _Cabezal con orificio facial.
- _Nivelador ajustable para evitar los pequeños desniveles.
- _Portarrollos opcional.
- _Peso soportado 200 kg.



Polipiel: ignífugo de categoría M2, antibacteriano, antimoho, antiséptico, antirayos UV, retardante de llama, impermeable, resistente a la transpiración, a la orina, la sangre y a la saliva humana.

🇬🇧 ELECTRIC examination couch, 3 sections

- _3 sections couch with electric height adjustment.
- _Epoxy-powder coated steel tube frame.
- _Electric height elevation, hand operated.
- _Mechanical adjustment of head section.
- _Mechanical adjustment of foot section.
- _Head section with breathing hole.
- _Adjustable foot for stability.

Leatherette: Fireproof M2, antimicrobial, antibacterial and antimycotic protection, urine and blood protection, UV light resistance, flame retardant, impermeability.

🇫🇷 Table d'examen ELECTRIQUE, 3 sections

- _Divan type fauteuil de 3 sections.
- _Structure en tube d'acier peint époxy.
- _Réglage de la hauteur par moteur électrique avec commande manuelle.
- _Dossier réglable par manivelle.
- _Jambière réglable par manivelle.
- _Avec orifice facial. Niveleur ajustable.

Similicuir: classement au feu M2, protection antimicrobienne, antibactérienne et antifongique; résistance à la transpiration, la salive humaine, l'urine et au sang; résistance à la lumière UV, Impermeabilité.

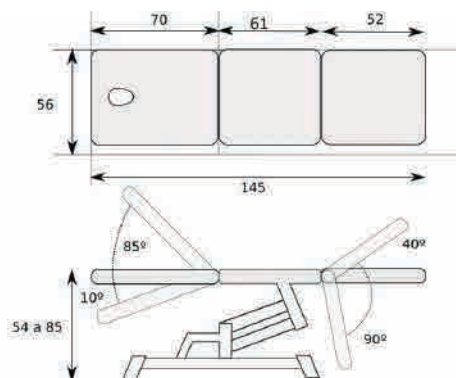

ACCESORIOS / ACCESSORIES / ACCESSOIRES



Reposabrazos plano tapizado.

Upholstered Armrest.
Accoudoirs tapisés.



Reposabrazos extracción de sangre.

Blood sampling arm-test.
Accoudoirs pour extraction du sang.



Tapón facial.

Breathing hole plug.
Bouchon facial.



Perneras individuales.

Leg-rest.
Repose-jambes.



M150

1450x560x540-880 mm

Camilla RECONOCIMIENTO PLEGABLE a pared, 2 secciones

M163-PL

- _Fabricada en acero esmaltado epoxy
- _Tapizado de gran densidad.
- _Cabezal abatible mediante cremallera (45°).

Examination table FOLDABLE , wall mounted, 2 sections

- _Manufactured in enamelled steel.
- _High density rubber upholstery.
- _Adjustable back-rest by ratchet system (45°).

Table d'examen PLIANT, fixé au mur, 2 sections

- _Fabriquée en acier peint.
- _Revêtement en skai de haute densité.
- _Dossier articulé par crémaillère (45°).



| | | |
|---------|-----------------|-------|
| M163-PL | 1800x550x700 mm | 27 kg |
|---------|-----------------|-------|

Camilla de RECONOCIMIENTO, 3 secciones

M172

- _Fabricada en acero inoxidable (M172) o esmaltado (M171).
- _Tapizado de gran densidad. Estructura soldada de gran solidez.
- _Cabecero y piecero articulado mediante cremallera.
- _Incluye nivelador en una de las patas.

EXAMINATION table, 3 sections

- _Manufactured in stainless (M172) or enamelled steel (M171).
- _High density rubber upholstery .Reinforced frame.
- _Articulated head-rest and leg-rest by ratchet system.
- _1 leveling teg.

Table d' EXAMEN 3 sections

- _Fabriquée en acier inoxydable (M172) ou peint (M171).
- _Revêtement en skai de haute densité. Armature renforcée.
- _Appui-tête et appui-pieds articulé par crémaillère.
- _1 aplanissement des jambes



| | | | |
|------|-----------------|-------|-------------|
| M171 | 1800x550x700 mm | 25 kg | Esmaltado |
| M172 | 1800x550x700 mm | 23 kg | Acero inox. |

Camilla exploración GINECOLÓGICA eléctrica, 3 secciones

M151

- _Estructura en tubo de acero esmaltado epoxi. 3 secciones.
- _Regulación de altura mediante motor eléctrico con mando de mano. Trendelemburg compensado.
- _Respaldo elevable/reclinable mediante pistón a gas.
- _Perneras ginecológicas regulables y giratorias.
- _Cojín cervical ergonómico
- _Bandeja de acero inoxidable extraíble bajo el asiento
- _Nivelador ajustable para evitar los pequeños desniveles.
- _Disponibile también modelo con respaldo elevable mediante motor eléctrico (M151-2).
- _Peso soportado 200 kg.

Polipiel: ignífugo de categoría M2, antibacteriano, antimoho, antisalínico, antirayos UV, retardante de llama, impermeable, resistente a la transpiración, a la orina, la sangre y a la saliva humana.

🇬🇧 GYNDECOLOGICAL electric examination couch

- _Epoxy-powder coated steel tube frame. 3 sections.
- _Electric height elevation, hand operated.
- _Mechanical adjustment of head and foot section.
- _Adjustable leg-rest, cushion and tray.
- _Also available model with electric adjustable back-rest (M151-2).
- _Trendetemburg.

Leatherette: Fireproof M2, antimicrobial, antibacterial and antimycotic protection, urine and blood protection, UV light resistance, flame retardant, impermeability.

🇫🇷 Fauteuil d'examen GINECOLOGIQUE électrique

- _Structure en tube d'acier peint époxy. 3 sections.
- _Réglage de la hauteur par moteur électrique avec commande manuelle. Niveleur ajustable.
- _Dossier et jambière réglable par manivelle. Avec orifice facial.
- _Modèle disponible avec dossier réglable électrique (M151-2).
- _Tredetemburg.

Similicuir: classement au feu M2, protection antimicrobienne, antibactérien et antifongique; résistance à la transpiration, la salive humaine, l'urine et au sang; résistance à la lumière UV, Impermeabilité



Foto con extras opcionales.



Foto con extras opcionales.

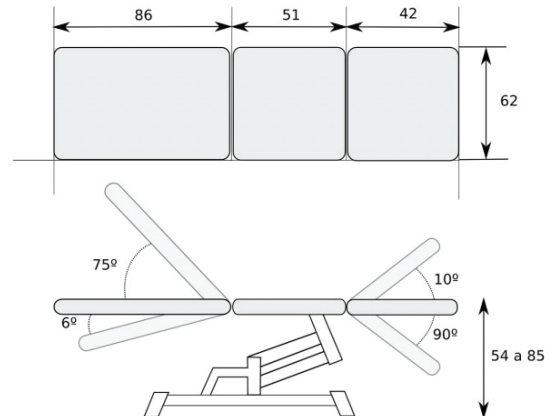

ACCESORIOS / ACCESSORIES / ACCESSOIRES



Reposabrazos regulable en altura y apertura.

Height and angle adjustable armrest. Accoudoirs réglable.



Estriberas.

Stirrups. Étriers.



Soporte colposcópico.

Colposcope storage. Support colposcopique.



Apoyabrazos abatible 180°.

Adjustable armrest 180°. Accoudoirs relevable 180°.



| | |
|--------|---------------------|
| M151 | 1840x620x540-880 mm |
| M151-2 | 1840x620x540-880 mm |



Otros accesorios disponibles. Ask us for more accessories. Consultez pour plus d'accessoires.

camillas

examination tables
tables d'examination

de reconocimiento / examination couch / table d'examen
ginecológica / gynaecology / gynecologique
camilla obesos / examination table obese / table d'examination obèses

Camilla GINECOLÓGICA 3 secciones

M153

- _Estructura en acero inoxidable, soldada de gran solidez.
- _Tapizado de gran densidad.
- _Cabecero y piecero articulado mediante cremallera.
- _Patas con protectores, una con nivelador.
- _Perneras tapizadas.
- _Banquillo de acceso.
- _Posición trendelemburg.
- _Cubeta para restos.

🇬🇧 Gynaecological Table

- _Manufactured in stainless steel, reinforced frame.
- _High density rubber upholstery .
- _Articulated head-rest and leg-rest by ratchet system.
- _1 leveling leg.
- _Upholstered legrest.
- _Single step.
- _Trendelenburg position.
- _Stainless steel basin.

🇫🇷 Table Gynecologique

- _Structure en acier inox, soudée solide.
- _Revêtement en skai de haute densité
- _Appui-tête et repose-jambes articulées par crémaillère.
- _Pieds sur vérins de stabilité.
- _Paire de jambières tapissés.
- _Marche pied.
- _Position de Trendelenburg.
- _Cuvette en inox escamoteable sous l'asise.



M153

1400x530x850 mm

38 kg

Camilla GINECOLÓGICA 3 secciones

M173

- _Fabricada a en acero inoxidable (M173) o esmaltado (M174).
- _Tapizado de gran densidad. Estructura soldada de gran solidez.
- _Cabecero y piecero articulado mediante cremallera.
- _Incluye nivelador en una de las patas.
- _Juego de perneras y estribos en acero inoxidable.

🇬🇧 GYNAECOLOGICAL table, 3 sections

- _Manufactured in stainless (M173) or enamelled steel (M174).
- _High density foam rubber upholstery.
- _Reinforced frame.
- _Articulated head-rest and leg-rest by ratchet system.
- _Set of leg-rest and foot-rest in stainless steel.

🇫🇷 Table d'examen GYNEOCOLOGIQUE, 3 sections

- _Fabriquée en acier inoxydable (M173) ou peint (M174).
- _Revêtement en skai de haute densité.
- _Armature renforcée.
- _Appui-tête et appui-pieds articulé par crémaillère.
- _Jeu d'appui jambes et appui-pieds en acier inox.



M173

1800x550x700 mm

28 kg

Acero inox.

M174

1800x550x700 mm

29 kg

Esmaltado

camillas

examination tables
tables d'examination

camilla obesos / examination table obese / table d'examination obèses
reconocimiento masaje / recognition massage / reconnaissance massage
accesorios / accessories / accessoires

Camilla OBESOS

M170

- _Estructura fija fabricada en acero esmaltado epoxy.
- _Agujero facial.
- _Peso soportado 300 kg.

🇬🇧 Examination table OBESE

- _Structure fixed manufactured in steel epoxy powder coated.
- _Facial hole.
- _Weight capacity 300 kg.

🇫🇷 Table d'examen OBÈSE

- _Structure fixed fabriqué en acier époxy peint.
- _Trou facial.
- _Capacité 300 kg .



ACCESORIOS / ACCESSORIES / ACCESSOIRES



Portarrollos
Paper roll holder
Porte-rouleaux

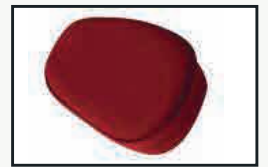

Tapón facial
Breathing hole plug
Bouchon facial



M170

1900x900x750 mm

27 kg

Camilla de RECONOCIMIENTO, 2 secciones, fija

M166

- _Fabricada en acero esmaltado (M165) o inoxidable (M166).
- _Varios anchos disponibles. Tapizado de gran densidad.
- _Estructura soldada de gran solidez.
- _Cabezal abatible mediante cremallera (45°).
- _Incluye nivelador en una de las patas
- _Modelo M166-P (PLUS) con estructura reforzada en tubo cuadrado, de acero inoxidable.

🇬🇧 EXAMINATION table, 2 sections, fixed.

- _Manufactured in enamelled (M165) or stainless steel (M166).
- _High density rubber upholstery.
- _Different available widths. Reinforced frame.
- _Adjustable backrest by ratchet mechanism (45°).
- _Model M166-P (PLUS) has reinforced structure of square tube in stainless steel.

🇫🇷 Table d' EXAMEN, 2 sections, fixé.

- _Fabriquée en acier inoxydable (M166) ou peint (M165).
- _Armature renforcée. Revêtement en skai de haute densité.
- _Appui-tête articulé par crémaillère (45°). Plusieurs largeurs disponibles.
- _Modèle M166-P (PLUS) avec structure renforcée en acier inox.



M166-P



M165
M166
M166-P

1800x550x700 mm
1800x550x700 mm
1800x550x700 mm

27 kg
25 kg
31 kg

Esmaltado
Acero inox.
Acero inox.

camillas

examination tables
tables d'examination

camilla obesos / examination table obese / table d'examination obèses
reconocimiento masaje / recognition massage / reconnaissance massage
accesorios / accessories / accessoires

Camilla de masaje MALETA

M175-A

- _Fabricada en aluminio, con tensores.
- _Tapizado en espuma de gran densidad (25 kg, 4 cm).
- _2 cuerpos, con orificio facial.
- _Plegable (70x91 cm), convertible en maleta, y elevable en altura.
- _Disponible modelo con respaldo articulado (-A).

🇬🇧 PORTABLE MASSAGE table

- _Manufactured in aluminium, with tensor.
- _High density foam rubber upholstery (25 kg, 4 cm).
- _2 sections, with breathing hole.
- _Folding (70x91 cm), portable, height adjustable.
- _Available model with articulated head rest (-A).



🇫🇷 Table de MASSAGE-VALISE

- _Fabriquée en aluminium, avec système de tendeurs.
- _Revêtement en mousse de haute densité (25 kg, 4 cm).
- _2 sections, avec trous de respiration.
- _Pliante (70x91 cm), transformable en valise, et hauteur réglable.
- _Disponible modèle avec appui-tête articulé (-A).

M175



| REF | ↔ ↑ ↙ | KG |
|--------|-----------------|-------|
| M175-A | 1820x700x830 mm | 12 kg |
| M175 | 1820x700x830 mm | 10 kg |

ACCESORIOS PARA CAMILLAS FIJAS / ACCESSORIES FOR TABLES / ACCESSOIRES POUR TABLES



Portarrollos cromado.
Paper roll support chromed.
Porte-rouleau papier chromé.

REF M499

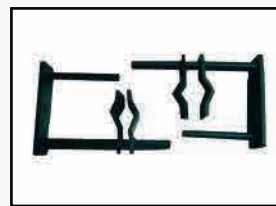

Portarrollos plástico.
Paper roll support in plastic.
Porte-rouleau papier en plastique.

REF M499-P



Orificio facial.
Breathing hole.
Trous de respiration.

REF MT904



Rollo de papel camilla 60 cm ancho.
Paper roll 60 cm width.
Rouleau papier 60 cm largeur.

REF M499-R



sillones

armchairs

fauteils

sillones

armchairs
fauteuils

extracciones / extractions
podología / podology / podologie
clinico / clinical / clinique

Silla EXTRACCIONES

M117-S

- _Fabricada en acero inoxidable.
- _Asiento y respaldo tapizado.
- _Incluye 1 (M117-S) o 2 (M117-S2) soportes de brazos.

EXTRACCIONS armchair

- _Manufactured in stainless steel tube.
- _Upholstered seat and back.
- _Includes 1 (M117-S) or 2 (M117-S2) armrests.

Fauteuil pour EXTRACCIONS

- _Fabriquée en tube de acier inoxydable.
- _Assise et dossier rembourrés.
- _Comprend 1 (M117-S) ou 2 (M117-S2) supporte de bras.

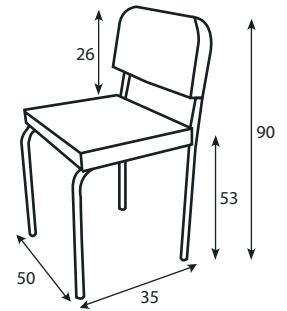

REF



KG

| | | |
|---------|----------------|-------|
| M117-S | 350x500x900 mm | 17 kg |
| M117-S2 | 350x500x900 mm | 19 kg |

Sillón EXTRACCIONES

M117

- _Fabricado en tubo de acero inoxidable.
- _Respaldo y reposapiés elevables manualmente hasta la posición horizontal.
- _Reposabrazos desmontables y regulables en altura.

EXTRACCIONS armchair

- _Manufactured in stainless steel tube.
- _Manually adjustable backrest and legrest to horizontal position.
- _Removable and adjustable armrests.

Fauteuil pour EXTRACCIONS

- _Fabriquée en tube de acier inoxydable.
- _Dossier et appui-pieds articulés manuellement jusqu'à la position horizontale.
- _Accoudoirs démontables et réglables.

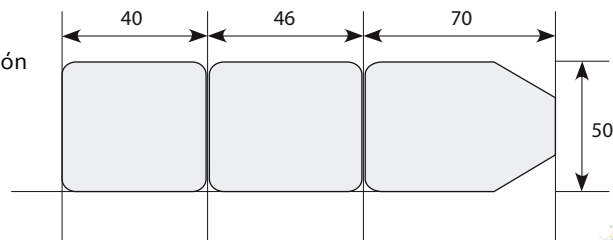

REF



KG

| | | |
|------|----------------|-------|
| M117 | 1556x500x530mm | 23 kg |
|------|----------------|-------|

sillones

armchairs
fauteuils

extracciones / extractions
podología / podology / podologie7
clinico / clinical / clinique

Sillón EXTRACCIONES

M117-M

- _Peso soportado 250 kg.
- _Altura fija. Reposabrazos regulables en altura y apertura.
- _Respaldo elevable/reclinable mediante palancas.
- _Reposacabezas regulable en altura.
- _Perneras independientes.
- _Perneras elevables/reclinables mediante palancas.
- _Pintura del chasis en gris antracita.
- _4 niveladores ajustables para evitar los pequeños desniveles.

Polipiel: ignífugo de categoría M2, antibacteriano, antimoho, antiséptico, antirayos UV, retardante de llama, impermeable, resistente a la transpiración, a la orina, la sangre y a la saliva humana.

EXTRACTIONS armchair

- _Weight supported 250 kg.
- _Fixed height. Adjustable armrests.
- _Mechanical adjustment of head section.
- _Height adjustable headrest.
- _Individual leg sections.
- _Manual adjustment of leg section.
- _Framework painted in anthracite grey.
- _4 adjustable feet for stability on uneven surfaces.

Leatherette: Fireproof M2, antimicrobial, antibacterial and antimycotic protection, urine and blood protection, UV light resistance, flame retardant, impermeability.

Fauteuil pour EXTRACTIONS

- _Poid Supporté 250 kg
- _Hauteur fixe. Accoudoirs réglables.
- _Dossier élevable/inclinable par leviers.
- _Repose-tête réglable en hauteur.
- _Jambières indépendantes.
- _Jambières relevables/inclinables par des leviers.
- _La peinture du châssis est en gris anthracite.
- _4 niveleurs ajustables pour éviter les petites pentes.

Similicuir: classement au feu M2, protection antimicrobienne, antibactérienne et antifongique; résistance à la transpiration, la salive humaine, l'urine et au sang; résistance à la lumière UV, Impermeabilité

ACCESORIOS / ACCESSORIES / ACCESSOIRES



Apoyabrazos abatible 180°.

Adjustable armrest 180°.
Accoudoirs oscillant 180°.



Portarrollos sillones.

Back paper roll holder.
Porte rouleaux fauteuil.

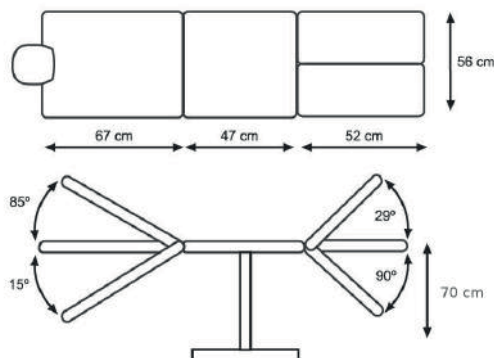

REF



M117-M

1660x560-700 mm

sillones

armchairs
fauteuils

extracciones / extractions
podología / podology / podologie
clinico / clinical / clinique

Sillón ELÉCTRICO PODOLOGÍA

- _Altura ajustable eléctricamente mediante mando manual.
- _Reposa-cabezas y reposa-piés regulables manualmente.
- _Perneras independientes y extensibles.
- _Reposabrazos abatibles.
- _Estructura de tubo de acero recubierto de polvo epoxi.
- _Niveladores ajustables para evitar posibles desniveles.
- _Relleno de espuma de 5 cm de grosor, densidad de 30 kg.
- _Trendelemburg.

Polipiel ignífuga de categoría M2, antibacteriano, antimoho, antisalínico, antirayos UV, retardante de llama.

🇬🇧 ELECTRICAL chair PODOLOGY

- _Height adjustable electrically by hand control.
- _Back-rest and head-rest adjustable manually.
- _Divided leg-section, with independent movements.
- _Foldable arm-rest.
- _Frame made of powder coated steel tube.
- _Upholstery 5cm thickness, density 30kg.
- _Trendelemburg.

Leatherette fireproof category M2, antibacterial, antimoho, antisalínico, lightning UV, flame retardant.

🇫🇷 Fauteuil ELECTRIQUE PODOLOGIE

- _Dossier relevable et appuie-tête extensible.
- _Jambières indépendantes et extensibles.
- _Accoudoirs rabattables.
- _Structure en tube d'acier laqué époxy.
- _Niveleur réglable pour compenser les petits dénivelés du sol.
- _Rembourrage en mousse de 5 cm d'épaisseur et la densité de 30 kg.
- _Trendelemburg.

Similicuir ignifugé de catégorie M2, antibactérien, anti-moisissures, anti salin, anti UV, et retardateur du feu.

ACCESORIOS / ACCESSORIES / ACCESSOIRES



Ruedas con freno individual.

Wheels with individual breaks.
Roues avec frein individuel.



Portarrollos sillones.

Back paper roll holder.
Porte rouleaux fauteuil.



M158-P

1800x620x340x850 mm

M158-P

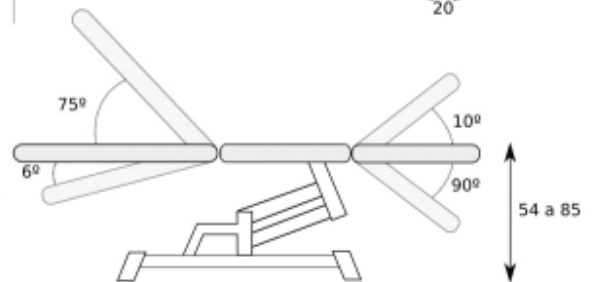
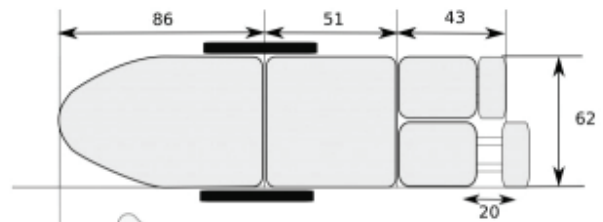

sillones

armchairs
fauteuils

extracciones / extractions
podología / podology / podologie
clinico / clinical / clinique

Sillón HEMODIÁLISIS Y QUIMIOTERAPIA

M117-EA

- _Estructura en acero pintado epoxi.
- _Regulable en altura mediante motor eléctrico con mando de mano.
- _Inclinación y elevación simultánea motorizada de respaldo y perneras
- _Tren y antitren motorizados.
- _Apoyabrazos para hemodiálisis y extracción, abatibles y giratorios
- _Reposapiés extraíble y regulable en altura.
- _Ruedas con freno individual.
- _Peso soportado 200 kg.

Polipiel ignífuga de categoría M2, antibacteriano, antimoho, antisalínico, antirayos UV, retardante de llama.

HEMODIALYSIS AND CHEMOTHERAPY Armchair

- _Epoxy painted steel structure.
- _Height adjustable by electric motor with hand control.
- _Backrest and legrest adjustable simultaneously by electric motor.
- _Position trendelenburg and reverse-trendelenburg by electric motor.
- _Armrest for hemodialysis and extractions, folding and swiveling.
- _Removable and height adjustable footrest.
- _Wheels with single brake.
- _Weight capacity: up to 200 kg.

Leatherette fireproof category M2, antibacterial, antimoho, antisalínico, lightning UV, flame retardant.

ROULANT Fauteuil POUR HÉMODIALYSE ET CHIMIOTHÉRAPIE

- _Poid Supporté 200 kg
- _Appui-pieds amovible.
- _Réglage de la hauteur par moteur électrique avec commande manuelle.
- _Trendelenburg - anti tren motorisés.
- _Inclination et élévation du dossier et des jambières, simultané et motorisé.
- _Accoudoirs pour extraction, pliants et rotatifs.
- _Roues de transport.
- _Le moteur/les moteurs se conforment aux normes de securité europeene
- _structure en tube d'acier recouvert de poussière époxy, cuite au four à 210°

Similicuir ignifugé de catégorie M2, antibactérien, anti-moisissures, anti salin, anti UV, et retardateur du feu.

ACCESORIOS / ACCESSORIES / ACCESSOIRES



Portarrollos sillones.

Back paper roll holder.
Porte rouleaux fauteuil.

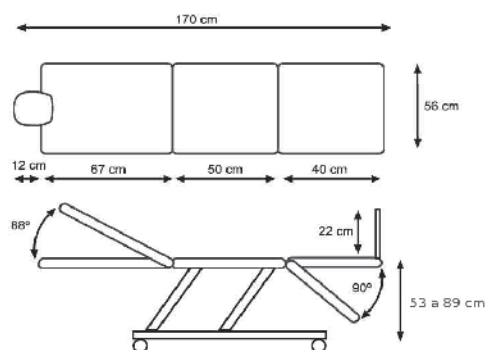

REF



M117-EA

1700x560x890 mm

sillones

armchairs
fauteuils

extracciones / extractions
podología / podology / podologie
clinico / clinical / clinique

Sillón CLÍNICO PACIENTE / ACOMPAÑANTE

MOSILL

- _Fabricado en acero esmaltado epoxy.
- _Respaldo modelado con espuma de de alta densidad, con cómodo acolch
- _Reposabrazos regulable en altura.
- _Inclinación de respaldo regulable mediante pistón a gas (0°-45°).
- _Soporte para piernas regulable, elevable automáticamente.
- _Dos ruedecillas traseras para poder mover el sillón cómodamente.
- _Opcional: cuatro ruedas, dos de ellas con freno, portasueros.
- _Peso máximo de usuario: hasta 130Kg

Tejido en polipiel, impermeable e ignífugo, de fácil limpieza.

Armchair FOR PATIENT / ATTENDANTS

- _Made in epoxy enamelled steel.
- _Backrest with high-density foam, with comfortable padding.
- _Height adjustable armrests.
- _Reclining backrest by gas spring (0°-45°).
- _Adjustable leg-rest automatically..
- _Two rear castors for an easy movement of armchair.
- _Option: four wheels, two with brakes, IV pole.
- _Maximum load capacity: up to 130Kg.

Synthetic leather, waterproof and fire resistant, easy to clean.



Posibilidad de incluir ruedas.
Possibility include wheels.
Possibilité comprendre des roues.

ROULANT chair POUR PATIENT / ATTENDANT

- _Fabriqué en acier émaillé époxy.
- _Dossier avec mousse de haute densité, avec un rembourrage confortable.
- _Accoudoirs réglables en hauteur.
- _Dossier inclinable, réglable par vérin à gaz (0°-45°).
- _Repose-pieds réglables automatiquement.
- _Deux roulettes arrières pour déplacer confortablement de chaise.
- _A choisir: quatre roues, deux avec frein, porte-sérum.
- _Poids supporté: jusqu'à 130 kg

Tissu similicuir, imperméable et résistant au feu, facile à nettoyer.

ACCESORIOS / ACCESSORIES / ACCESSOIRES



Portasueros.

Carry serum.

Sérum de report.



Brazos para diálisis y/o extracciones, regulable y abatible.

Armrests for dialysis and / or extractions, adjustable and foldable

Accoudoirs pour la dialyse et / ou extractions, réglable et pliable



Patas regulables.

Adjustable legs.

Piédés réglables.



MOSILL

720x870x1540 mm

Sillón CLÍNICO PARA DIALISIS / EXTRACCIONES

M271-CD

- _Estructura de gran robustez, en acero pintado epoxi.
- _Respaldo abatible por cilindro a gas con trendelemburg.
- _Reposapiernas abatible independiente por cilindro a gas.
- _Con brazos para diálisis y/o extracciones, regulable y abatible.
- _Reposapiernas y apoyapiés escamoteables bajo asiento.
- _Asidero de empuje en respaldo y dos acoples portasueros.
- _4 ruedas, 2 de 125 mm con freno + 2 de 100 mm.



DYALISIS / EXTRACTIONS Armchair

- _High resistance structure, made in epoxy painted steel.
- _Adjustable backrest by gas cylinder with trendelemburg.
- _Adjustable legrest by gas cylinder.
- _Armrests for dialysis and / or extractions, adjustable and foldable.
- _Retractable legrest and footrest under the seat.
- _Push handle at back side and two IV pole supports.
- _4 wheels, 2 Ø125mm with brakes and 2 Ø100mm.

ROULANT Fauteuil DE DIALYSE / EXTRACTIONS

- _Structure de haute résistance, fabriqué en acier peint époxy.
- _Dossier réglable par vérin à gaz avec trendelemburg.
- _Repose-jambes réglable par vérin à gaz.
- _Accoudoirs pour la dialyse et / ou extractions, réglable et pliable.
- _Repose-jambes et repose-pieds escamotables sous le siège.
- _Poignée sur le côté arrière et two raccords porte sérums
- _4 roues, 2 Ø125mm avec freins et 2 Ø100mm.

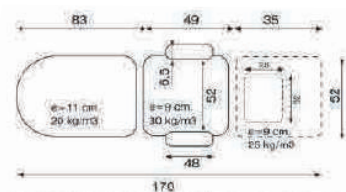
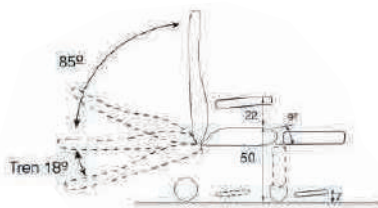

Medidas Totales Sentado: Ancho 65 x Largo 81 x Alto 113 cm.

REF



KG

M271-CD

650x810x113 mm

33 kg

sillones

armchairs
fauteuils

extracciones / extractions
podología / podology / podologie
clinico / clinical / clinique

Sillón GERIÁTRICO CLÍNICO

- _Estructura de gran robustez, en acero pintado epoxi.
- _Respaldo y reposapiés abatibles sincronizado por cilindro a gas.
- _Reposabrazos abatibles.
- _Asidero de empuje en respaldo. 2 acoples portasueros.
- _Opcional ruedas de 80Ø, 2 con freno.
- _Medidas totales sentado ancho 650 x largo 810 x1130mm de alto

🇬🇧 Armchair

- _High resistance structure, made in epoxy painted steel.
- _Adjustable backrest and legrest by gas cylinder synchronized.
- _Folding armrests.
- _Push handle at back side and 2 IV pole supports.
- _Option: wheels Ø80mm, 2 with brakes.
- _Dimensions (sitting): 650x810x1130mm.

🇫🇷 Fauteuil

- _Structure de haute résistance, fabriqué en acier peint époxy.
- _Dossier réglable par vérin à gaz synchronisé avec repose-jambes.
- _Accoudoirs rabattables.
- _Poignée sur le côté arrière et 2 raccords porte sérums
- _Option: roues Ø80mm, 2 avec freins.
- _Dimensions (assis): 650x810x1130mm



M271-A



Posibilidad de incluir ruedas.
Possibility include wheels.
Possibilité comprendre des roues.

Sillón GERIÁTRICO CLÍNICO

- _Estructura de gran robustez, en acero pintado epoxi.
- _Respaldo abatible por cilindro a gas.
- _Reposapiernas abatible independiente por cilindro a gas.
- _Reposabrazos abatibles.
- _Apoyapiés escamoteable bajo asiento.
- _4 ruedas, 2 de 125 mm con freno + 2 de 100 mm.
- _Asidero de empuje en respaldo. 2 acoples portasueros.

🇬🇧 Armchair ON WHEELS

- _High resistance structure, made in epoxy painted steel.
- _Adjustable backrest by gas cylinder.
- _Adjustable legrest by gas cylinder
- _Folding armrests.
- _Retractable footrest under the seat.
- _Push handle at back side and 2 IV pole supports.
- _4 wheels, 2 Ø125mm with brakes and 2 Ø100mm.

🇫🇷 Fauteuil ROULANT

- _Structure de haute résistance, fabriqué en acier peint époxy.
- _Dossier réglable par vérin à gaz.
- _Repose-jambes réglable par vérin à gaz.
- _Accoudoirs rabattables.
- _Repose-pieds escamotable sous le siège.
- _Poignée sur le côté arrière et 2 raccords porte sérums
- _4 roues, 2 Ø125mm avec freins et 2 Ø100mm.



M272-R



M271-A
M272-A

650x810x1130 mm
650x810x1130 mm

sillones

armchairs
fauteuils

extracciones / extractions
podología / podology / podologie
clinico / clinical / clinique

Sillón reclinable

M272-B

- _Estructura en acero pintado (gris o negro).
- _Goma espuma de alta densidad, revestido en skai.
- _Respaldo regulable manualmente en 3 posiciones.
- _Reposapiés regulable.
- _Apoyabrazos de poliuretano.

ADJUSTABLE Archair

- _Structure in painted steel (grey or black).
- _High-density foam, covered in leatherette.
- _Manually adjustable backrest in 3 positions.
- _Adjustable footrest.
- _Polyurethane armrests.



Fauteuil RÉGLABLE

- _Structure en acier peint (gris ou noir).
- _Mousse haute densité, recouvert de similicuir.
- _Dossier réglable en 3 positions.
- _Repose-pieds réglable.
- _Accoudoirs en polyuréthane.



M272-B

590x480x1140 mm

30 kg

Sillón TRASLADO respaldo

M268

- _Estructura en madera de haya.
- _Asiento y respaldo tapizados.
- _Respaldo alto, fijo.
- _Reposa-brazos.
- _Kit de traslado en acero pintado.
- _Ruedas Ø100mm, 2 con freno.
- _Reposapiés escamoteable.
- _Dos asideros en la parte trasera para facilitar el desplazamiento.

Armchair ON WHEELS, FIXED BACK-REST

- _Wooden beech structure.
- _Upholstered back-rest and seat-rest.
- _High fixed back-rest.
- _Arm-rest.
- _Rolling base in enamelled steel.
- _Wheels Ø100mm, 2 with brakes.
- _Detachable foot-rest.
- _Two handles for an easy movement.

Fauteuil ROULANT, DOSSIER FIXÉ

- _Structure en bois de hêtre.
- _Dossier et assise tapissés.
- _Dossier haute, fixe.
- _Accoudoirs.
- _Base roulant en acier peint.
- _Roues Ø100mm, dont 2 à frein.
- _Repose-pieds
- _Two poignées pour un déplacement facile.



M268 (Respaldo fijo)

610x780x1200 mm

M268-F (Respaldo reclinable) 610x780x1200 mm

Sillón respaldo alto

M267

- _Estructura en madera de haya.
- _Asiento y respaldo tapizados.
- _Respaldo alto, reclinable manualmente.
- _Reposa-brazos.

Tapicería: goma espuma alta densidad. Tela vinílica con protección antimicrobial, antibacterial y antimicótica. Alta resistencia a la abrasión, sangre y orina. Ignífugo M2. Lavable.

Reclining armchair

- _Wooden beech structure.
- _Upholstered back-rest and seat-rest.
- _High back-rest, adjustable manually.
- _Arm-rest.

Upholstered: high density rubber foam. Vynil with antimicrobial, antibacterial and antimycotic protection. High resistance to abrasion, blood and urine. Fireproof M2. Washable.

Fauteuils RÉGLABLE

- _Structure en bois de hêtre.
- _Dossier et assise tapissés.
- _Dossier haute, réglable manuellement.
- _Accoudoirs.

Tapicerie: mousse à haute densité. Vinyle avec protection antimicrobienne, antibactérienne et antifongique. Haute résistance à l'abrasion, sang et urine. Ignifuge M2. Lavable.



M267

610x720x1200 mm

Silla RESPALDO FIJO

M263

- _Estructura en madera de haya.
- _Asiento y respaldo tapizados.
- _Respaldo bajo, fijo.
- _Reposa-brazos

Tapicería: goma espuma alta densidad. Tela vinílica con protección antimicrobial, antibacterial y antimicótica. Alta resistencia a la abrasión, sangre y orina. Ignífugo M2. Lavable.

FIXED chair

- _Wooden beech structure.
- _Upholstered back-rest and seat-rest.
- _Fixed back-rest.
- _Arm-rest.

Upholstered: high density rubber foam. Vynil with antimicrobial, antibacterial and antimycotic protection. High resistance to abrasion, blood and urine. Fireproof M2. Washable.

Fauteuil FIXE

- _Structure en bois de hêtre.
- _Dossier et assise tapissés.
- _Dossier fixe.
- _Accoudoirs.

Tapicerie: mousse à haute densité. Vinyle avec protection antimicrobienne, antibactérienne et antifongique. Haute résistance à l'abrasion, sang et urine. Ignifuge M2. Lavable.



M263

600x800x890 mm

Reposapiés BASCULANTE

M270

- _Estructura en madera de haya.
- _Tapizado con goma espuma y tejido vinílico.
- _Basculante.

Tapicería: goma espuma alta densidad. Tela vinílica con protección antimicrobial, antibacterial y antimicótica. Alta resistencia a la abrasión, sangre y orina. Ignífugo M2. Lavable.

RECLINING Leg-rest

- _Wooden beech structure.
- _Upholstered.
- _Reclining.

Upholstered: high density rubber foam. Vynil with antimicrobial, antibacterial and antimycotic protection. High resistance to abrasion, blood and urine. Fireproof M2. Washable.

Repose-James JAMBES INCLINABLE

- _Structure en bois de hêtre.
- _Tapissé.
- _Inclinable.

Tapiceriess: mousse à haute densité. Vinyle avec protection antimicrobienne, antibactérienne et antifongique. Haute résistance à l'abrasion, sang et urine. Ignifuge M2. Lavable.



M270

460x460x460 mm

Sillón respaldo alto reclinable

M267-R

- _Estructura en madera de haya.
- _Asiento y respaldo tapizados.
- _Respaldo alto, reclinable manualmente.
- _Reposapiernas, 3 posiciones.
- _Reposa-brazos.

Tapicería: goma espuma alta densidad. Tela vinílica con protección antimicrobial, antibacterial y antimicótica. Alta resistencia a la abrasión, sangre y orina. Ignífugo M2. Lavable.

RECLINING Armchair

- _Wooden beech structure.
- _Upholstered back-rest and seat-rest.
- _High back-rest, adjustable manually.
- _Adjustable leg-rest, 3 positions.
- _Arm-rest.

Upholstered: high density rubber foam. Vynil with antimicrobial, antibacterial and antimycotic protection. High resistance to abrasion, blood and urine. Fireproof M2. Washable.

Fauteuil RÉGLABLE

- _Structure en bois de hêtre.
- _Dossier et assise tapissés.
- _Dossier haute, réglable manuellement.
- _Repose-pieds elevable, 3 positions.
- _Accoudoirs.

Tapiceriess: mousse à haute densité. Vinyle avec protection antimicrobienne, antibactérienne et antifongique. Haute résistance à l'abrasion, sang et urine. Ignifuge M2. Lavable.



M267-R

610x780x1200 mm

sillones

armchairs
fauteuils

podología / podology / podologie
clinico / clinical / clinique
sillones / armchairs / fauteuils

Sillón FIJO, 2 o 3 PLAZAS

M274-3

- _Estructura en madera de haya.
- _Asiento y respaldo tapizados.
- _Respaldo alto fijo.
- _Reposa-brazos.
- _Disponible de 2 y 3 plazas.

Armchair FIXED, 2 OR 3 SEATS

- _Wooden beech structure.
- _Upholstered back-rest and seat-rest.
- _Fixed back-rest.
- _Arm-rest.
- _Available with 2 or 3 seats.



Fauteuil FIXE, 2 et 3 PLACES.

- _Structure en bois de hêtre.
- _Dossier et assise tapissés.
- _Dossier fixe.
- _Accoudoirs.
- _Disponible: 2 ou 3 places.



M274-2



| | |
|--------|------------------|
| M274-3 | 1640x780x1200 mm |
| M274-2 | 1000x780x1200 mm |

Sillón LEVANTA PERSONAS

M260

- _Composición: madera de pino barnizada, goma espuma y tejido vinílico.
- _Armazón reforzado.
- _Respaldo reclinable.
- _Reposapiés abatible.
- _Regulable por motor eléctrico, con mando de mano.

POWER LIFT Armchair

- _Wooden beech structure.
- _Reinforced frame.
- _Upholstered back-rest and seat-rest.
- _Reclining back-rest.
- _Adjustable leg-rest.
- _Electric motor, hand operated.

Fauteuil LÈVE PERSONS

- _Structure en bois de hêtre.
- _Dossier et assise tapissés.
- _Dossier réglable.
- _Repose-pieds elevable.
- _Moteur électrique avec commande de main.



| | |
|------|----------------------|
| M260 | 700x800x1000-1300 mm |
|------|----------------------|

sillones

armchairs
fauteuils

clinico / clinical / clinique
sillones / armchairs / fauteuils
sofá cama / sofa bed / canapé-lit

Sillón reclinable BRAZO DESMONTABLE

M261

- _Composición: madera de pino barnizada, goma espuma y tejido vinílico.
- _Armazón reforzado.
- _Respaldo y reposapiés abatibles manualmente.
- _Brazo desmontable.

Reclining armchair WITH DETACHABLE ARMREST

- _Wooden beech structure.
- _Reinforced frame.
- _Upholstered back-rest and seat-rest.
- _Adjustable back-rest and leg-rest, hand operated.
- _Detachable arm-rest.



Fauteuil AVEC BRAS DÉTACHABLE

- _Structure en bois de hêtre.
- _Dossier et assise tapissés.
- _Dossier et repose-pieds réglable, manuellement.
- _Bras détachable.



REF



M261

780x800x1002 mm

Sofá cama 1 PLAZA

M262

- _Estructura en madera de haya. Respaldo y asiento moldeado con forma ergonómica. Somier plegable. Apertura frontal.
- _Incluye colchon de 80x190.

Tapicería: goma espuma alta densidad. Tela vinílica con protección antimicrobial, antibacterial y antimicótica. Alta resistencia a la abrasión, sangre y orina. Ignífugo M2. Lavable.

Sofa bed

- _Wooden beech structure. Ergonomic back and seat. Folding bed base.
- _Front opening. It includes mattress 80x190.

Upholstered: high density rubber foam. Vinyl with antimicrobial, antibacterial and antimycotic protection. High resistance to abrasion, blood and urine. Fireproof M2. Washable.

Canapé-lit

- _Structure en bois de hêtre. Sauvegarde et siège ergonomique.
- _Pliant sommier. Ouverture frontale.
- _Comprend un matelas 80x190.

Tapicerie: mousse à haute densité. Vinyle avec protection antimicrobienne, antibactérienne et antifongique. Haute résistance à l'abrasion, sang et urine. Ignifuge M2. Lavable.



REF



M262

900x900x900 mm



taburetes

stools

tabourets

taburetes

stools
tabourets

manual / manualley / manuel
a gas / hydraulic / par vérin

Taburete giratorio

M200

- _Fabricada en acero esmaltado (M201) o acero inoxidable (m200).
- _Regulable en altura manualmente.
- _Asiento de Ø33 cm, tapizado en skay.
- _Accesorios: ruedas.

REVOLVING stool

- _Framework made of epoxy powder coated steel (M201), or stainless steel (M200).
- _Height adjustable manually.
- _Seat- rest Ø33cm, upholstered.
- _Option: castors.

Tabouret TOURNANT

- _Bâti en acier revêtement époxy polyester (M201) ou acier inoxydable (M200).
- _R'eglable en hauteur manuellement.
- _Assise en mousse Ø33 cm, recouvert de simili-cuir.
- _A choisir: roues.



| REF | ↔ ↻ ↕ | KG |
|------|--------------------|------|
| M200 | 500x500x500-700 mm | 3 kg |
| M201 | 500x500x500-700 mm | 4 kg |

Taburetes LABORATORIO

M205-IB

- _Fabricado en acero esmaltado o acero inoxidable (-I).
- _Regulable en altura manualmente.
- _Asiento de Ø33 cm, tapizado en skay.
- _Modelos con o sin respaldo (-B).

LABORATORY stools

- _Framework made of epoxy powder coated steel, or stainless steel (-I).
- _Height adjustable manually.
- _Seat- rest Ø33cm, upholstered.
- _Models with or without back-rest (-B).

Tabourets pour LABORATOIRE

- _Bâti en acier revêtement époxy polyester ou acier inoxydable (-I).
- _Réglable en hauteur manuellement.
- _Assise en mousse Ø33 cm, recouvert de simili-cuir.
- _Modèles avec o sans dossier (-B).

M205-I



| REF | ↔ ↻ ↕ | KG | |
|---------|----------------------|------|-------------|
| M205-B | 500x500x600-750 mm | 7 kg | Esmaltado |
| M205-IB | 500x500x600-750 mm | 7 kg | Acero inox. |
| M205 | 500x500x1050-1250 mm | 8 kg | Esmaltado |
| M205-I | 500x500x1050-1250 mm | 8 kg | Acero inox. |

taburetes

stools
tabourets

manual / manually / manuel
a gas / hydraulic / par vérin

Taburetes a GAS sin respaldo

- _Taburete regulable en altura por pistón metálico a gas.
- _Asiento de Ø33 cm, tapizado en skay.
- _Base en polipropileno o de aluminio.
- _5 ruedas de Ø50 mm o topes antideslizantes (-T).
- _Disponible modelo con pistón alto (-L).
- _Accesorio: reposapiés.

🇬🇧 HYDRAULIC pump stools

- _Revolving stool, adjustable by gas spring (metallic).
- _Seat- rest 33cm, upholstered. 5 wheels Ø50 mm or stoppers.
- _Polypropilene or metallic base. Option: foot rest
- _Available: high spring model (-L).

🇫🇷 Tabourets réglables par VÉRIN

- _Hauteur variable par verin à gaz (metallique).
- _Assise en mousse Ø33 cm, recouvert de simili-cuir.
- _Piètement en polipropilene ou alluminium.
- _Avec 5 roulettes de Ø50 mm ou patins.
- _Accessoire: repose-pieds.
- _Disponible: modèle avec vérin long (-L).

M20014



M20010



-T



REF



KG

| | | |
|----------|--------------------|------|
| M20010 | 560x560x540-730 mm | 5 kg |
| M20014 | 520x520x540-730 mm | 5 kg |
| M20010-L | 560x560x600-860 mm | 6 kg |
| M20014-L | 520x520x600-860 mm | 6 kg |

Taburetes a GAS con respaldo

- _Taburete regulable en altura por pistón a gas metálico. Asiento de Ø33 cm.
- _Asiento y respaldo tapizado en skay. Pistón metálico.
- _Base en polipropileno o aluminio. 5 ruedas Ø50mm o topes antideslizantes (-T). Accesorio: reposapiés. Disponible modelo con pistón alto (-L).

🇬🇧 HYDRAULIC pump stools

- _Revolving stool, adjustable by gas spring metallique. Seat- rest Ø33 cm.
- _Upholstered seat-rest and back-rest. Metallic piston.
- _Polypropilene or aluminum base. 5 antistatics wheels Ø50mm or stoppers (-T). Available: High spring model (-L). Option: foot-ring.

🇫🇷 Tabourets réglables par VÉRIN

- _Hauteur variable par verin à gaz. Assise en mousse Ø33 cm.
- _Dossier et assise recouvert de simili-cuir.
- _Piètement en polipropilene ou alluminium. Accessoire: repose-pieds.
- _Avec 5 roulettes Ø50mm ou patins.
- _Disponible: modèle avec vérin long (-L).

M20015



M20011



REF



KG

| | | |
|----------|--------------------|------|
| M20011 | 560x560x540-730 mm | 7 kg |
| M20015 | 520x520x540-730 mm | 7 kg |
| M20011-L | 520x520x600-860 mm | 8 kg |
| M20015-L | 520x520x600-860 mm | 8 kg |

taburetes

stools
tabourets

manual / manualley / manuel
a gas / hydraulic / par vérin

Taburetes a GAS asiento ancho

- _Taburete regulable en altura por pistón metálico a gas.
- _Asiento ancho con respaldo tapizado en skay.
- _Base en polipropileno o de aluminio.
- _5 ruedas de Ø50 mm o topes antideslizantes (-T).
- _Accesorio: reposapiés.

🇬🇧 HYDRAULIC pump stools

- _Revolving stool, adjustable by gas spring (metallic).
- _Wide seat- rest.
- _Upholstered seat-rest and back-rest.
- _Polypropilene or aluminum base.
- _5 wheels Ø50 mm or stoppers (-T).
- _Option: foot-ring

🇫🇷 Tabourets réglables par VÉRIN

- _Hauteur variable par verin à gaz (métallique).
- _Assise large.
- _Dossier et assise recouvert de simili-cuir.
- _Piètement en polipropilene ou aluminium.
- _Avec 5 roulettes Ø50 mm ou patins (-T)
- _À choisir: repose-pieds.

M20011-AG



M20015-AG



REF



KG

| | | |
|-----------|--------------------|------|
| M20011-AG | 560x560x540-730 mm | 9 kg |
| M20015-AG | 520x520x540-730 mm | 9 kg |

Taburetes a GAS ERGONÓMICO

- _Taburete regulable en altura por pistón (metallic).
- _Asiento ergonómico, tapizado en skay.
- _Base en polipropileno o aluminio.
- _5 ruedas de Ø50 mm o topes antideslizantes (-T).
- _Accesorio: reposapiés.

🇬🇧 HYDRAULIC ERGONOMIC pump stools

- _Revolving stool, adjustable by gas spring (metallic).
- _Ergonomic seat- rest, upholstered.
- _Polypropilene or aluminum base.
- _5 wheels Ø50mm or stoppers (-T).
- _Option: foot-ring.

🇫🇷 Tabourets réglables par VÉRIN ERGONOMIQUE

- _Hauteur variable par verin à gaz (métallique).
- _Assise ergonomique, recouvert de simili-cuir.
- _Piètement en polipropilene ou aluminium.
- _À choisir: repose-pieds.
- _Avec 5 roulettes antistatiques de Ø50mm ou patins (-T).

M20010-ERGO



M20014-ERGO



REF



KG

| | | |
|-------------|--------------------|------|
| M20010-ERGO | 560x560x540-730 mm | 5 kg |
| M20014-ERGO | 520x520x540-730 mm | 5 kg |

taburetes

stools
tabourets

manual / manuel
a gas / hydraulic / par vérin

Taburetes a GAS CROMADO

- _ Taburete regulable en altura por pistón (metálico) a gas.
- _ Asiento de Ø35 cm, cromado.
- _ Base en polipropileno o aluminio.
- _ Accesorio: reposapiés.
- _ 5 ruedas Ø50 mm o topes antideslizantes (-T).

🇬🇧 CHROMED HYDRAULIC pump stools

- _ Revolving stool, adjustable by gas spring (metallic).
- _ Seat- rest Ø35 cm, chromed. Long metallic piston.
- _ Polypropilene or aluminum base.
- _ Option: foot-ring
- _ 5 wheels Ø50 mm or stoppers.

🇫🇷 Tabouretes réglables par VÉRIN CHROMÉS

- _ Hauteur variable par verin à gaz (metallec).
- _ Assise en mousse Ø35 cm.
- _ Piètement en polipropilene ou aluminium.
- _ À choisir: repose-pieds.
- _ Avec 5 roulettes Ø50 mm ou patins.

M20020-A



M20020-P



| | | |
|----------|--------------------|------|
| M20020-P | 560x560x540-730 mm | 6 kg |
| M20020-A | 520x520x540-730 mm | 6 kg |

Taburetes a GAS POLIURETANO

- _ Taburete regulable en altura por pistón a gas.
- _ Asiento y respaldo en poliuretano.
- _ Pistón cromado y base de aluminio.
- _ Incluye reposapiés.
- _ 5 ruedas Ø50 mm o topes antideslizantes (-T).

🇬🇧 HYDRAULIC pump stools, POLYURETHANE

- _ Revolving stool, adjustable by gas spring (chromed).
- _ Seat-rest and back-rest in polyurethane.
- _ Aluminum base.
- _ Includes foot-ring.
- _ 5 wheels Ø50 mm or stoppers.

🇫🇷 Tabouretes réglables par VÉRIN, POLYURÉTHANE

- _ Hauteur variable par verin à gaz(chromaé).
- _ Dossier et assise de polyuréthane.
- _ Piètement d'aluminium.
- _ Inclus repose-pieds.
- _ Avec 5 roulettes Ø50 mm ou patins.

M20019-R



M20018-R



| | | |
|----------|--------------------|------|
| M20018-R | 560x560x600-860 mm | 8 kg |
| M20019-R | 520x520x600-860 mm | 9 kg |

taburetes

stools
tabourets

manual / manuel
a gas / hydraulic / par vérin

Taburetes a GAS MADERA

- _ Taburete regulable en altura por pistón metálico a gas.
- _ Asiento y respaldo en madera barnizada.
- _ Base en polipropileno o en aluminio.
- _ Incluye reposapiés.
- _ 5 ruedas Ø50 mm o topes antideslizantes (-T).
- _ Accesorios: reposapiés.

🇬🇧 Hydraulic pump stools, VARNISHED WOOD

- _ Revolving stool, adjustable by gas spring, metallic piston.
- _ Seat-rest and back-rest in varnished wood.
- _ Polypropilene or aluminum base.
- _ Includes foot-ring.
- _ 5 wheels Ø50 mm or stoppers (-T).
- _ Option: foot-ring.

🇫🇷 Tabourets réglables par vérin, EN BOIS VERNI

- _ Hauteur variable par vérin à gaz, piston métallique.
- _ Dossier et assise en bois verni.
- _ Piètement en polipropilene ou en aluminium.
- _ Inclus repose-pieds.
- _ Avec 5 roulettes Ø50 mm ou patins (-T).
- _ A choisir: repose-pieds.

M20017-R



M20016-R



| | | |
|----------|--------------------|------|
| M20016-R | 520x520x600-860 mm | 8 kg |
| M20017-R | 560x560x600-860 mm | 9 kg |

Taburete a gas con BRAZOS

- _ Taburete giratorio elevación a gas.
- _ Asiento amplio tapizado en skaï
- _ Respaldo tapizado.
- _ Regulable en altura por pistón a gas.
- _ Base con 5 brazos en ABS.
- _ Con ruedas Ø50mm o topes (-T).
- _ Brazos y reposapiés.
- _ Opciones disponibles.

🇬🇧 Hidraulic pump stool with ARMREST

- _ Swivel stool gas elevation..
- _ Ample seat upholstered in skaï upholstered backrest .
- _ Adjustable in height by gas piston.
- _ Base with 5 arms in ABS.
- _ With wheel Ø50mm or stoppers (-T).
- _ Arms and footrest.
- _ Option available.

🇫🇷 Tabourets réglables par vérin avec ARMES.

- _ Swivel élévation de gaz de selles.
- _ Ample siège rembourré en skaï dossier rembourré .
- _ Réglable en hauteur par piston à gaz.
- _ Base 5 - bras avec salle de bains ABS.
- _ Avec roues Ø50mm ou patins (-t).
- _ Option bras et repose-pieds.



Detalle reposapiés
ABS



Detalle reposapiés
Cromado

M20011-B



| | | |
|----------|--------------------|------|
| M20011-B | 560x560x540-730 mm | 8 kg |
|----------|--------------------|------|



vitriñas

cabinet

vitrine

Vitrina con 1 PUERTA

- _Fabricada en acero esmaltado.
- _Puerta de cristal con cerradura.
- _3 estantes de cristal.
- _Disponible modelo con base en acero inoxidable y 4 estantes (-I).

Cabinet with DOOR

- _Framework made of enamelled steel sheet.
- _Glass door, with lock and key.
- _3 glass shelves.
- _Available: model with stainless steel base and 4 shelves (-I).

Vitrine avec UNE PORTE

- _Bâti en acier revêtement époxy polyester.
- _Porte en vitre à fermeture.
- _Avec 3 étagères en vitre.
- _Modèle avec base en acier inoxydable et 4 étagères (-I).

M6004-I



M6004



| REF | Dimensions (mm) | Weight (kg) |
|---------|-----------------|-------------|
| M6004 | 600x300x1400 mm | 34 kg |
| M6004-I | 600x350x1500 mm | 35 kg |

Vitrina con 2 PUERTAS

- _Fabricada en acero esmaltado.
- _Laterales y puertas de cristal, con cerradura.
- _3 estantes de cristal.
- _2 modelos: con puertas correderas (M6005) o batientes (M6006).

Cabinet with 2 DOOR

- _Manufactured in enamelled steel.
- _Glass sides and glass doors, with lock and key.
- _3 glass shelves.
- _2 models: sliding doors (M6005) or swinging doors (M6006).

Vitrine avec 2 PORTES

- _Bâti en acier revêtement époxy polyester.
- _Les côtés et les portes en vitre, avec serrure.
- _Avec 3 étagères en vitre.
- _2 modèles: portes coulissantes (M6005) ou portes battantes (M6006).

M6005



M6006



| REF | Dimensions (mm) | Weight (kg) |
|-------|-----------------|-------------|
| M6005 | 600x300x1400 mm | 16 kg |
| M6006 | 600x300x1400 mm | 16 kg |

vitrinas

cabinets
vitrines

simple / simple / simple
con armario / with cupboard / avec armoire
con puertas correderas / sliding doors / portes coulissantes

Vitrina con ARMARIO

M6003

- _Fabricada en acero esmaltado o inoxidable (-I).
- _Parte superior con laterales y puertas de cristal, con cerradura.
- _2 estantes de cristal.
- _Parte inferior con dos puertas en acero, con cerradura.
- _Estante inferior de acero.

Cabinet with CUPBOARD

- _Framework made of enamelled or stainless steel (-I).
- _Upper part with glass sides and glass doors, with lock and key.
- _2 glass shelves.
- _Lower part with two steel doors, with lock and key.
- _Lower shelf in steel.

Vitrine avec ARMOIRE

- _Bâti en acier revêtement époxy polyester ou acier inoxydable (-I).
- _Partie supérieure avec les côtés et les portes en vitre, avec serrure.
- _Avec 2 étagères en vitre.
- _Partie inférieure avec 2 portes en acier à fermeture.
- _Avec 1 étagère en acier.

M6003-I



| | | |
|---------|-----------------|-------|
| M6003 | 600x300x1400 mm | 25 kg |
| M6003-I | 600x300x1400 mm | 25 kg |

Vitrina ARMARIO GRANDE

M6007

- _Fabricada en acero esmaltado o inoxidable (-I).
- _Parte superior con laterales y puertas de cristal, con cerradura.
- _2 estantes de cristal.
- _Parte inferior con dos puertas en acero, con cerradura.
- _Estante inferior de acero.

Cabinet with CUPBOARD

- _Framework made of enamelled or stainless steel (-I).
- _Upper part with glass sides and glass doors, with lock and key.
- _2 glass shelves.
- _Lower part with two steel doors, with lock and key.
- _Lower shelf in steel.

Vitrine avec ARMOIRE

- _Bâti en acier revêtement époxy polyester ou acier inoxydable (-I).
- _Partie supérieure avec les côtés et les portes en vitre, avec serrure.
- _Avec 2 étagères en vitre.
- _Partie inférieure avec 2 portes en acier à fermeture.
- _Avec 1 étagère en acier.

M6007-I



| | | |
|---------|------------------|-------|
| M6007 | 1000x400x1600 mm | 35 kg |
| M6007-I | 1000x400x1600 mm | 35 kg |

vitriñas

cabinets
vitrines

simple / simple / simple
con armario / with cupboard / avec armoire
con puertas correderas / sliding doors / portes coulissantes

Vitrina INSTRUMENTAL

- _ Construida en acero inoxidable (M6010) o esmaltado (M6008).
- _ Puertas correderas de cristal con cerradura.
- _ 4 estantes de cristal.
- _ Base en acero inoxidable.

🇬🇧 INSTRUMENTAL cabinet

- _ Manufactured in stainless steel (M6010) or enamelled (M6008).
- _ Sliding glass doors, with lock and key.
- _ 4 glass shelves.
- _ Stainless steel base.

🇫🇷 Vitrine à INSTRUMENTS

- _ Construit en acier inoxydable (M6010) ou peint (M6008).
- _ Portes coulissantes en verre à fermeture.
- _ Avec 4 étagères en verre.
- _ Base en acier inoxydable.

M6010



M6008



| | | |
|-------|-----------------|-------|
| M6008 | 900x350x1600 mm | 60 kg |
| M6010 | 900x350x1600 mm | 60 kg |

Vitrina MURAL

- _ Fabricada en acero esmaltado o inoxidable (-I).
- _ Puertas correderas de cristal con cerradura.
- _ 1 ó 2 estantes de cristal.

🇬🇧 WALL Cabinet

- _ Framework made of enamelled or stainless steel (-I).
- _ Two sliding glass doors, with lock and key.
- _ 1 or 2 glass shelves.

🇫🇷 Vitrine MURALE

- _ Bâti en acier revêtement époxy polyester ou acier inoxydable (-I).
- _ Portes coulissantes en vitre avec serrure.
- _ 1 ou 2 étagères en vitre.

M6002



M6001



| | | |
|---------|----------------|-------|
| M6001 | 700x250x500 mm | 15 kg |
| M6001-I | 700x250x500 mm | 15 kg |
| M6002 | 900x250x500 mm | 20 kg |
| M6002-I | 900x250x500 mm | 20 kg |

Vitrina SIMPLE

M6011

- _Fabricada en acero esmaltado, color gris claro.
- _Puerta de cristal con marco en acero inoxidable y cerradura.
- _4 estantes en cristal regulables en altura.
- _4 patas cromadas.

SIMPLE cabinet

- _Made in enameled steel, (grey colour)
- _Glass door with stainless steel frame and lock.
- _Four crystal shelves, adjustable in height.
- _Four chromed legs.

Vitrine SIMPLE

- _Fait en acier peint, (couleur grise).
- _Porte en verre avec serrure.
- _4 étagères en verre, réglables.
- _4 jambes chromée.



M6011

600x400x1800 mm

50 kg

Vitrina DOBLE

M6012

- _Fabricada en acero esmaltado, color gris claro.
- _Parte superior con 2 puertas de cristal con marco en acero inoxidable y cerradura.
- _3 estantes en cristal, regulables en altura.
- _Parte inferior con 2 puertas en acero y estante de acero
- _4 patas cromadas.

DOUBLE cabinet

- _Made in enameled steel, (grey colour).
- _Upper part with 2 glass door with stainless steel frame and lock.
- _3 crystal shelves, adjustable in height.
- _Lower part with 2 doors in stainless steel and one steel shelf.
- _4 chromed legs.

Vitrine DOUBLE

- _Fait en acier peint, (couleur grise).
- _Partie supérieure avec 2 portes 2 en verre avec serrure.
- _3 étagères en verre, réglables.
- _Partie inférieure avec 2 portes en acier et une étagère en acier.
- _4 jambes chromée.



M6012

800x400x1800 mm

85 kg



auxiliar

auxiliary

auxiliar

auxiliar

auxiliary
auxiliar

banquillos / steps / marche pieds
negatoscopios / negatoscopes / negatoscopes
focos / focus / lampes

Banquillos

- _Fabricados en acero esmaltado o acero inoxidable.
- _1 ó 2 peldaños.
- _Superficie antideslizante (de goma o acero inoxidable).
- _Disponible modelo con asidero.
- _Topes de goma.
- _Posibilidad de fabricación a medida.

🇬🇧 FOOTS Steps

- _Manufactured in enamelled steel or stainless steel.
- _1 or 2 steps.
- _Anti-slip platform (rubber or stainless steel).
- _Available model with handle.
- _Rubber feet.
- _Custom-made possibility.

🇫🇷 Marche PIEDS

- _Fabriqué en acier émaillé ou en acier inoxydable.
- _1 ou 2 marches..
- _Surface antidérapante (caoutchouc ou en acier inoxydable).
- _Modèle disponible avec poignée.
- _Pare-chocs en caoutchouc.
- _Possibilité de fabrication sur mesure.

M006



M009



M006-G



M009-I



M006-IB



M006-I



FM0119



REF



KG

| | | |
|---------|-----------------|--------|
| M006 | 500x210x210 mm | 3 kg |
| M009 | 415x480x410 mm | 6 kg |
| M006-G | 410x490x210 mm | 3 kg |
| M006-IB | 415x480x410 mm | 6 kg |
| M006-I | 400x200x200 mm | 3 kg |
| FM0119 | 600x800x1350 mm | 9 kg |
| M009-I | 400x400x450 mm | 5,4 kg |

auxiliar

auxiliary
auxiliar

banquillos / steps / marche pieds
negatoscopios / negatoscopes / negatoscopes
focos / focus / lampes

Negatoscopios

- _Fabricado en acero pintado o en acero inox. (-A).
- _Fijación mural.
- _Iluminación por fluorescencia
- _Pantalla de metacrilato blanco opal
- _Interruptor por pantalla.
- _Pantallas independientes de 36 x 43 cm
- _Sistema de fijación por gravedad, para las radiografías
- _Voltaje a 220 V. 50 Hz
- _Clavija Schuko.
- _Opción: regulador de luz.

🇬🇧 Negatoscopes

- _Made of painted steel or stainless steel (-A).
- _Wall mounted.
- _Fluorescent lighting
- _White methacrylate screen.
- _Independent screens 36 x 43 cm
- _Fixing system by gravity.
- _220 V 50 Hz
- _Plug Schuko
- _Option: Light regulator

🇫🇷 Negatoscopes

- _Fabriqué en acier peint ou inoxydable (-A).
- _L'éclairage fluorescent.
- _Écran de méthacrylate blanc opale.
- _Écrans indépendants 36 x 43 cm
- _Système de fixation par gravité.
- _Tension 220 V 50 Hz
- _Fiche: Schuko
- _À choisir: regulateur de lumière.

M221



M220

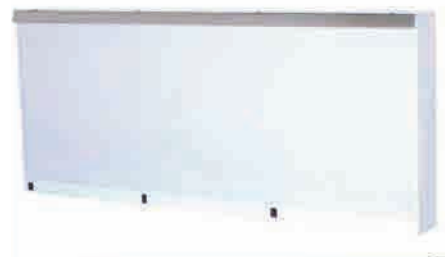

M222



| REF | | KG | |
|------|-----------------|-------|--------|
| M220 | 380x110x480 mm | 5 kg | Simple |
| M221 | 750x110x480 mm | 9 kg | Doble |
| M222 | 1110x110x480 mm | 12 kg | Triple |

Negatoscopios LED

- _Marco de aluminio.
- _Luz LED.
- _Bajo consumo y bajo calentamiento de pantalla.
- _Temperatura de color 6500° K.
- _3 tamaños disponibles.
- _Disponible atril para sobremesa.

🇬🇧 LED Negatoscopes

- _Aluminum frame.
- _LED light.
- _Low power consumption and low heat screen.
- _3 available measurements.
- _Option: portable lectern.

🇫🇷 Negatoscopes LED

- _Cadre en aluminium.
- _Lumière LED.
- _Faible consommation d'énergie et à faible écran thermique.
- _La température de couleur 6500 ° K.
- _3 tailles disponibles.
- _Disponible: lutrin portable.

M234-A



M235



| REF | exterior / extérieur | interior / intérieur | KG |
|--------|----------------------|----------------------|-------|
| M235 | 365x280x26 mm | 290x205 mm | 5 kg |
| M234-A | 420x490x26 mm | 350x420 mm | 7 kg |
| M236-P | 490x820x26 mm | 420x750 mm | 10 kg |

auxiliar

auxiliary
auxiliar

negatoscopios / negatoscopes / negatoscopes
focos / lamps / lampes
biombos / rolling screens / paravents

Foco de EXPLORACIÓN “Basic”

M194-P

- _Estructura de acero y cromada.
- _Foco orientable en todos los sentidos.
- _Luminosidad uniforme.
- _Base de plástico.
- _5 ruedas Ø50 mm doble rodadura.

EXAMINATION lamp “Basic”

- _Chromed and steel structure.
- _Orientable focus in all directions.
- _Uniform light
- _Plastic base.
- _5 wheels Ø50 mm.

Lampe d' EXPLORATION “Basic”

- _Structure en acier chromé.
- _Écran orientable dans tous les sens.
- _Luminosité uniforme.
- _Base en plastique.
- _5 roulettes Ø50 mm.



REF



KG

M194-P

Ø640x950x1900 mm

9 kg

Foco de EXPLORACIÓN “Classic”

M195

- _Estructura cromada.
- _Foco orientable en todos los sentidos.
- _Luminosidad uniforme.
- _100W, 1400 lumenes.
- _5 ruedas Ø50 mm.
- _Base de plástico

EXAMINATION lamp “Basic”

- _Chromed structure.
- _Orientable focus in all directions.
- _Uniform light
- _100W, 1400 lumenes.
- _5 wheels Ø50 mm.
- _Plastic base.

Lampe d' EXPLORATION “Basic”

- _Structure en acier chromé.
- _Ecran orientable dans tous les sens.
- _Luminosité uniforme.
- _100W, 1400 lumenes.
- _5 roulettes Ø50 mm.
- _Base en plastique.



REF



KG

M195

Ø560x600x950-1900 mm

9 kg

Foco INFRARROJO

M197

- _Foco orientable.
- _Bombilla de 250 W.
- _Longitud de onda 0,76 a 1,4 micras.
- _Altura regulable.
- _Base cromada con cinco ruedas Ø50 mm.
- _Opción reloj minuterero

INFRARED lamp

- _Orientable focus.
- _250W bulb.
- _Height adjustable.
- _Chromed base with 5 wheels Ø50 mm.

Lampe à INFRA-ROUGES

- _Écran orientable.
- _Lampe de 250W.
- _Hauteur réglable.
- _Base chromé avec 5 roulettes Ø50 mm.



aisi 307
18/10



M197

Ø700x600x130-180 mm

10 kg

Foco de EXPLORACIÓN

M194-HF

- _Plástico ABS.
- _Diseñado para la máxima reducción de calor.
- _Luz fría.
- _35W, 50000 lux.
- _Temperatura de color 3.000°K.
- _5 ruedas de Ø50 mm.
- _Base de plástico.

EXAMINATION lamp

- _ABS plastic.
- _for maximum heat reduction.
- _Cold light.
- _35W, 50000 lux.
- _Color temperature 4.000°K.
- _5 wheels Ø50 mm.
- _Plastic base.

Lampe d' EXPLORATION

- _Plastique ABS.
- _Conçu pour la réduction maximale de la chaleur.
- _Lumi lumière froide.
- _35W, 50000 lux.
- _Température de couleur 4.000°K.
- _5 roulettes Ø50 mm.
- _Base en plastique.



M194-HF

Ø640x950 -1900 mm

9 kg

Foco de EXPLORACIÓN “Lupa”

M198-5

- _Luminosidad uniforme, tubo fluorescente circular de 22W.
- _Soporte articulado orientable y regulable en altura.
- _Base metálica Ø64.
- _5 ruedas de Ø50 mm doble rodadura.
- _Lupa de 5 dioptrías.
- _Disponible en versión led.

EXAMINATION lamp “Lens”

- _Uniform light, fluorescent tube 22W circular.
- _Support articulated swiveling and regulable in height.
- _Metallic base Ø64.
- _5 wheels Ø50 mm double rolling.
- _Magnifying glass 5 diopters.
- _Available in version led.

Lampe d’ EXPLORATION “Loupe”

- _Luminosité uniforme, tube fluorescent circulaire 22 W.
- _Support articulé pivotant et réglable à hauteur.
- _Hauteur réglable.
- _Base en métal Ø64.
- _5 roulettes Ø50 mm double laminage.
- _Loupe 5 dioptries.
- _Disponible version led.



M198-5

Ø640x950-1900 mm

9 kg

Foco de EXPLORACIÓN

M195-H

- _Radio de giro 85 cm.
- _Baja temperatura.
- _Sin radiación infrarroja.
- _35W, 50000 lux.
- _Temperatura de color 4.000°K.
- _Base de plástico Ø64 mm
- _5 ruedas de Ø50 mm.
- _Opción LED.

EXAMINATION lamp

- _Turning radius 85 cm.
- _Low temperature.
- _No infrared radiation.
- _35W, 50000 lux.
- _Color temperature 4.000°K.
- _5 wheels Ø50 mm.
- _Plastic base Ø64 mm
- _Option LED.

Lampe d’ EXPLORATION

- _Rayon de braquage 85 cm.
- _Temperature faible.
- _No infrared radiation.
- _35W, 50000 lux.
- _Température de couleur 4.000°K.
- _5 roulettes Ø50 mm.
- _Base en plastique Ø64 mm.
- _Option LED.



M195-H

600x600x950-1900 mm

9 kg

auxiliar

auxiliary
auxiliar

focos / lamps / lampes
biombos / rolling screens / paravents
soportes / supports

Biombos

- _Fabricado en acero esmaltado o inoxidable.
- _2 o 3 cuerpos.
- _Telas plastificadas desmontables. Paneles plegables.
- _Opción: tela con motivos infantiles (M019-I).
- _Ruedas de Ø40 mm.

Rolling SCREEN

- _Structure made of enamelled or stainless steel.
- _2 or 3 pannels.
- _Plastic clothes, removable. Folding panels.
- _Option: child clothes (M019-I).
- _Castors Ø40 mm.

Paravents

- _Structure fabriquée en acier epoxy ou acier inox.
- _2 ou 3 panneaux.
- _Toile en plastique, démontables. Éléments indépendants pliables.
- _À choisir: toile infantile (M019-I).
- _Roulettes de Ø40 mm.



M027



M022

M019-I



aisi 304
18/10

| REF | ↔ ↙ ↕ | KG | Acabado |
|------|------------------|------|-------------|
| M022 | 1340x470x1700 mm | 7 kg | Esmaltado |
| M023 | 1340x470x1700 mm | 7 kg | Acero inox. |
| M025 | 1970x470x1700 mm | 9 kg | Esmaltado |
| M027 | 1970x470x1700 mm | 9 kg | Acero inox. |

Porta sueros GRAN CAPACIDAD

- _Fabricado en acero inoxidable AISI 304 18/10.
- _Disponibile con 4 o 6 ganchos (M029-A-GC-6).
- _Base aluminio Ø640mm.
- _Con 5 ruedas Ø50mm.
- _Regulable en altura: 2250 mm.
- _Asidero para facilitar la subida.

Serum holder GREAT CAPACITY

- _Made of stainless steel AISI 304 18/10.
- _Available with 4 or 6 hooks.
- _Aluminum base Ø640mm.
- _With 5 wheels Ø50mm.
- _Adjustable height: 2250 mm.
- _Easy rise handle.

Support de serum GRANDE TAILLE

- _Fabriqué en acier inoxydable AISI 304 18/10.
- _Disponibile avec 4 ou 6 crochets.
- _Base en aluminium Ø640mm.
- _Avec 5 roulettes Ø50mm.
- _Réglable en hauteur: 2250 mm.
- _Poignée pour téléchargement facile.



M029-A-GC-4

aisi 304
18/10

| REF | ↔ ↙ ↕ | KG |
|-------------|----------------|------|
| M029-A-GC-4 | Ø1180x-2250 mm | 7 kg |

auxiliar

auxiliary
auxiliar

biombos / rolling screens / paravents
soportes / supports / supports
podoscopios / footmeters / podoscopes

Portasueros

- _Fabricado en acero inoxidable. 2 o 4 ganchos (-4).
- _Ajustable en altura (1100-2000 mm).
- _Base en ABS (-P) o aluminio (-A), con 5 ruedas Ø50 mm.
- _Modelo con base en acero inoxidable y ruedas de Ø40 mm (M030).
- _Modelo con 4 ganchos en ABS (M029-ECO).
- _Disponible también modelo de techo (M033) y cama (M031).

🇬🇧 SERUM holder

- _Manufactured in stainless steel structure. 2 or 4 hooks (-4).
- _Height adjustable (1100-2000 mm).
- _ABS (-P) or aluminium (-A) base with 5 castors Ø50 mm.
- _Model with stainless steel base and 4 castors Ø40mm (M030).
- _Model with 4 ABS hooks (M029-ECO).
- _Available ceiling mounted model (M033) and for bed (M031).

🇫🇷 Support de SERUM

- _Structure fabriquée en acier inoxydable 02 ou 4 crochets (-4).
- _Réglables en hauteur (1000-2000 mm).
- _Base (-P) en ABS ou chromé (-A) avec 5 roulettes Ø50 mm.
- _Nouveau modèle avec 4 crochets d'ABS (M029-ECO).
- _Modèle avec base en acier inoxydable et 4 roulettes Ø40 mm (M030).
- _Modèle avec 4 brochets d'ABS (M029-ECO).
- _Aussi disponible modèle de plafond (M033) et de lit (M031).

Porta sueros infantiles

Kids serum holder
Support de serum pour enfants



i Consultenos para más información.

Consult us for more information.

Consultez-nous pour en savoir plus.

REF



KG

| | | |
|----------|--------------------|------|
| M029-P | Ø 560x1100-2000 mm | 3 kg |
| M029-A | Ø 490x1100-2000 mm | 3 kg |
| M029-ECO | Ø 560x1100-2000 mm | 3 kg |
| M030 | Ø 500x1100-2000 mm | 3 kg |

M029-P



M029-A



M029-ECO



auxiliar

auxiliary
auxiliar

biombos / rolling screens / paravents
soportes / supports / supports
podoscopios / footmeters / podoscopes

PORTA SUEROS con bandeja

M029-PB

- _Fabricados en acero inoxidable.
- _Con bandeja extraíble en acero inoxidable.
- _Base rodable en aluminio (M029-AB) o ABS (M029-PB).
- _5 ruedas de Ø50 mm.

🇬🇧 SERUM holder with tray

- _Made of stainless steel.
- _Tray in stainless steel
- _Rolling base in aluminum (M029-AB) or ABS (M029-PB).
- _5 wheels Ø50 mm.

🇫🇷 SUPPORT de serum avec plateau

- _Fabriqué en acier inoxydable.
- _Plateau en acier inoxydable.
- _Rodable base en aluminium (M029-AB) ou ABS (M029-PB)
- _5 roues Ø50 mm.



| REF | ↙ ↕ | KG |
|---------|--------------------|------|
| M029-PB | Ø 540x1100-2000 mm | 5 kg |
| M029-AB | Ø 490x1100-2000 mm | 5 kg |

SOPORTE de aparatos

- _Fabricados en acero inoxidable.
- _Diseñado para transportar aparatos de electromedicina.
- _Base rodable en aluminio con 5 ruedas de Ø50 mm.
- _Posibilidad de fabricación a medida.

🇬🇧 Equipment SUPPORT

- _Made of stainless steel.
- _Designed to carry equipment electromedicine.
- _Aluminum base with 5 wheels Ø50 mm.
- _Possibility custom tailor made.

🇫🇷 SUPPORT pour équipements

- _Fabriqué en acier inoxydable.
- _Conçu pour transporter équipement electromedicine.
- _Base en aluminium avec 5 roues Ø50 mm.
- _Possibilité de fabrication sur mesure.



| REF | ↙ ↕ | KG |
|----------|-------------------|------|
| M029-C | Ø 490x750 mm | 5 kg |
| M029-MC | Ø490x1100-2000 mm | 5 kg |
| M029-MC2 | Ø 490x750 mm | 4 kg |
| M029-MC3 | Ø 490x750 mm | 4 kg |

auxiliar

auxiliary
auxiliar

biombos / rolling screens / paravents
soportes / supports
podoscopios / footmeters / podoscopes

SOPORTE con perfil de aluminio

MED800

- _Base en acero inoxidable. Columna en perfil de aluminio de gran resistencia.
- _Soporte VESA, regulable en altura.
- _Atril abatible, fabricado en resina fenólica compacta.
- _Base de conexión eléctrica.
- _4 ruedas Ø80mm, 2 con freno.
- _Accesorios: portasueros, cesta almacenamiento...
- _Consultar otras configuraciones posibles.

🇬🇧 Alluminium profile SUPPORT

- _Stainless steel base. Support column in aluminium of great resistance.
- _VESA holder, height adjustable.
- _Collapsible board made of phenolic resin.
- _Electrical feeding plug.
- _4 wheels Ø80mm, two with brakes.
- _Accessories: serum holder, storage basket...
- _Please, consult other possible configurations

🇫🇷 Table à LANGER

- _Base en acier inoxydable. Colonne en profil d'aluminium de grande résistance.
- _Support VESA, réglable en hauteur.
- _Pupitre abattable, fabriqué en résine phénolique compacte.
- _Base de connexion électrique.
- _4 roues Ø80mm, deux avec frein.
- _Accessoires: porte-serum, panier stockage...
- _Consulter d'autres configurations possibles.



MED800

600x450x1200-1600 mm

Soporte BRAZOS Y PIERNAS

- _Estructura en acero inoxidable.
- _Regulable en altura.
- _Peana de ABS con 5 apoyos.
- _Soporte en acero inoxidable o tapizado.

🇬🇧 ARMS AND LEG HOLDER support

- _Manufactured in stainless steel.
- _Height adjustable.
- _ABS base with 5 foot.
- _Stainless steel or upholstered support.

🇫🇷 Support pour BRAS OU JAMBES

- _Fabriquée en acier inoxydable.
- _Réglable en hauteur.
- _Base en ABS avec 5 pieds.
- _Support en acier inoxydable ou metalassé.

M191

M193



(Brazos)



(Piernas)



M190

Ø560x700-1100 mm

5 kg

Acero inox.

M191

Ø560x700-1100 mm

5 kg

Tapizado

M192

Ø560x700-1100 mm

5 kg

Acero inox.

M193

Ø560x700-1100 mm

5 kg

Tapizado

auxiliar

auxiliary
auxiliar

biombos / rolling screens / paravents
soportes / supports / supports
podoscopios / footmeters / podoscopes

Porta PALANGANAS

- _ Fabricado en acero inoxidable.
- _ Regulable en altura.
- _ Incluye 1 o 2 palanganas de Ø360 mm.
- _ Base de aluminio con 5 ruedas Ø50 mm .

🇬🇧 BASIN HOLDER support

- _ Manufactured in stainless steel.
- _ Height adjustable.
- _ 1 or 2 stainless steel basin Ø360 mm.
- _ Metallic base with 5 rolling wheels Ø50 mm.

🇫🇷 Porte COUVETTES

- _ Fabriquée en acier inoxydable.
- _ Réglable en hauteur.
- _ 1 ou 2 cuvettes Ø360 mm.
- _ Base métallique avec 5 roulettes Ø50 mm.

M188

M187



REF



KG

| REF | Dimensions | Weight | Configuration |
|------|------------------|--------|---------------|
| M187 | Ø490x900-1200 mm | 4 kg | Simple |
| M188 | Ø640x900-1200 mm | 6 kg | Doble |

Carro PORTABALAS

- _ Construido en acero esmaltado epoxy.
- _ Estructura de tubo de acero 25 mm.
- _ Correa de sujeción.
- _ M036 para bombonas hasta Ø140 m.
- _ M035 para bombonas hasta Ø230 m.

🇬🇧 OXIGEN CYLINDER cart

- _ Enamelled steel construction.
- _ Tubular frame 25 mm.
- _ Holder strap.
- _ For small and big oxigen cylinders.
- _ M036 for cilinder up to Ø140 m.
- _ M035 for cilinder up to Ø230 m.

🇫🇷 Gueridon pour BOUTEILLE

- _ Construit en acier peint.
- _ Tube de 25 mm.
- _ Courroie pour soutenir les bouteilles.
- _ Pour grandes et petites bouteilles d'oxygen.
- _ M036 pour bouteilles just'à Ø140 m.
- _ M035 pour bouteilles just'à Ø230 m.

M036



M035



REF



KG

| REF | Dimensions | Weight |
|------|-----------------|--------|
| M035 | 350x750x1100 mm | 18 kg |
| M036 | 300x300x980 mm | 7 kg |

auxiliar

auxiliary
auxiliar

podoscopios / footmeters / podoscopes
optotipos / charts eye test / optotipes
básculas / scales / pèse-personnes

Podoscopio

M500

- _Fabricado en acero cromado
- _Baldosa de apoyo desmontable
- _Espejo, uno fijo y otro abatible, con regulación manual
- _Goniómetro desplazable con indicador
- _Iluminación eléctrica por fluorescencia

Footmeter

- _Made in chromed steel
- _Detachable support tile
- _Mirror, one fixed and one folding adjustable manually.
- _Movable goniometer with indicator
- _Fluorescent lighting.

Podoscope

- _Fabriqué en acier chromé
- _Support amovible
- _Miroirs, l'un fixe et un pliage, avec réglable manuellement
- _Goniomètre mobile avec indicateur
- _Éclairage fluorescent



M500

600x450x330 mm

5 kg

Optotipos

- _Estructura en acero esmaltado.
- _Iluminación por fluorescencia.
- _Voltaje de 220 V, 50 Hz
- _Modelos para adulto y niño.

Chart eye test

- _Enamelled steel structure.
- _Fluorescent lighting
- _Voltage 220 V, 50 Hz
- _Models for adult and child.

Optotipe

- _Fabriquée en acier peint.
- _Eclairage fluorescent.
- _Tension 220 V, 50 Hz
- _Modèles pour adult et enfant.

M240

M241



M240

450x110x380 mm

5 kg

Adulto

M241

450x110x380 mm

5 kg

Infantil

Báscula clase III ELECTRÓNICA

M211-CE

- _Plataforma con 2 ruedas.
- _Pantalla de LCD de 29 mm.
- _Seleccionable peso en kg o en libras.
- _Puesta a cero automática.
- _Función TARA y HOLD.
- _Apagado automático.
- _Opción tallímetro.
- _Fuente de alimentación: red y baterías.

🇬🇧 ELECTRONIC scale, class III

- _Plataform with 2 castors.
- _LCD screen 29 mm.
- _Weight in kg or pounds.
- _Automatic zero setting.
- _Auto switch off.
- _Function: TARE and HOLD.
- _Option: height rod.
- _Power by mains and batteries.

🇫🇷 Pèse-personne classe III ÉLECTRONIQUE

- _Plataform avec 2 roues.
- _Écran en LCD de 25mm.
- _Possibilité de sélectionner le poids en kg ou les livres.
- _Remise à zéro automatique.
- _Function TARE et HOLD.
- _Function arrêt automatique.
- _Fonction: l'indice de masse corporelle.
- _A choisir: taille



Especificaciones técnicas:
Capacidad: 220 kg
Sensibilidad: 100 g
Dimensiones de la
plataforma: 36 x 320 mm

Technical specifications:
Capacity: 220 kg
Sensitivity: 100 gr
Tray: 2310 x 275 mm

Caractéristiques techniques:
Capacité: 220 kg
Sensibilité: 100 gr
Plateau: 36 x 320 mm



M211-CE

392x320x1014 mm

8 kg

Báscula MECÁNICA con tallímetro

M219

- _Lectura de las escalas por ambos lados.
- _Tallímetro y ruedas incorporados.
- _Construcción de alta calidad, báscula compacta.
- _Parte superior: hierro fundido. Plataforma antideslizante.
- _Rango de medición del tallímetro: 750-2000 mm, graduación 5 mm.
- _Clase III opcional (M219-CE).

🇬🇧 MECHANICAL scale with height Rod

- _Reading of the scales by both sides
- _Built-in height rod and wheels.
- _Construction of high quality, compact scale.
- _Upper part: iron. Non sliding platform.
- _Range of measurement of height rod: 750-2000 mm, graduation 5 mm.
- _Option: Class III (M219-CE).

🇫🇷 Pèse-personne MÉCANIQUE

- _Lire les échelles des deux côtés.
- _Avec taille de mesure et roues.
- _Construction de haute qualité, bascule compacte.
- _Partie supérieure: fer. Plate-forme antidérapante
- _Plage de mesure du taille: 750-2000 mm, graduation 5 mm.
- _A choisir: Classe III (M219-CE).



Báscula con
Tallímetro



Especificaciones técnicas:
Capacidad: 200 kg
Sensibilidad: 100 g
Dimensiones de la
plataforma: 270 x 300 mm

Technical specifications:
Capacity: 200 kg
Sensitivity: 100 gr
Tray: 270x300 mm

Caractéristiques techniques:
Capacité: 200 kg
Sensibilité: 100 gr
Plateau: 270x 300 mm



M219

270x300 mm

15 kg

M219-CE

270x300 mm

15 kg

auxiliar

auxiliary
auxiliar

básculas / scales / pèse-personnes barras seguridad / security
barras de seguridad / safety bars / barres de sécurité
cestas a. inox / basket / paniers

Barras SOPORTE Y SEGURIDAD

_Fabricadas en acero inoxidable.
_Varios modelos y medidas.

🇬🇧 SECURITY aids

_Manufactured in stainless steel.
_Several models and measures.

🇫🇷 Barres D'APPUI ET DE SÉCURITÉ

_Fabriquée en acier inoxydable.
_Plusieurs modèles et mesures.

C01



A01



E400



D01



B01



| REF | ↔ ↙ ↕ | KG |
|------|----------------|------|
| A01 | 830x760x140 mm | 2 kg |
| B01 | 815x425x80 mm | 2 kg |
| C01 | 315x515x140 mm | 2 kg |
| D01 | 840x200 mm | 2 kg |
| E400 | 400 mm | 1 kg |

Cestas de ACERO INOX.

_Construidas en varillas de acero inoxidable.
_Consultar otras medidas.

🇬🇧 Baskets in STAINLESS STEEL

_Manufactured in stainless steel.
_Consult for others measures.

🇫🇷 Paniers en ACIER INOX.

_Fabriquée en acier inoxydable.
_Consultez autres mesures.



| REF | ↔ ↙ ↕ |
|--------|----------------|
| MCES25 | 470x244x155 mm |
| MCES35 | 470x294x155 mm |
| MCES40 | 470x344x155 mm |
| MCES45 | 470x394x155 mm |
| MCES50 | 470x444x155 mm |
| MCES55 | 470x544x155 mm |

Cestas de ACERO INOX. ESTERILIZACIÓN

MCES14

- _Construidas en varillas de acero inoxidable.
- _Consultar otras medidas disponibles.
- _Disponibles con rebaje en un lado.

Basket STAINLESS STEEL

- _Manufactured in stainless steel.
- _Available several measures.
- _Available with recess on one side.

Paniers de ACIER INOX.

- _Fabriquée en acier inoxydable.
- _Consultez sur plus mesures.
- _Disponible achancre dans un côté.

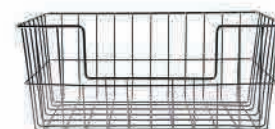

Con rebaje



| | |
|--------|----------------|
| MCES14 | 570x300x150 mm |
| MCES20 | 570x300x200 mm |
| MCES22 | 570x300x300 mm |

Racks en ACERO INOX.

MR-1100

- _Construidos en acero inoxidable.
- _Incluyen ganchos para colgar cestas.
- _Disponibles modelos mural o con ruedas.
- _Consultar otras medidas disponibles.
- _Disponibles accesorios de almacenaje.

STAINLESS STEEL Racks

- _Manufactured in stainless steel.
- _It includes hooks for hanging.
- _Available models wall or with wheels.
- _Consult available measures.
- _Available accessories storage.

Racks en ACIER INOX.

- _Fabriquée en acier inoxydable.
- _Il comprend crochets pour suspension.
- _Disponible modèles pour mur et avec roulettes.
- _Consultez sur plus mesures.
- _Disponible accessoires des stockage.



| | | |
|---------|---------|-----------|
| MR-1100 | 1100 mm | 3 ganchos |
| MR-2000 | 2000 mm | 6 ganchos |

Bandejas GASTRONORM

_Bandejas Gastronorm normalizadas bajo norma Europea EN-631.
_Construidas en acero inoxidable.

Trays in STAINLESS STEEL

_Gastronorm trays under European standard EN-631.
_Built in stainless steel.

Plateaux en ACIER INOX.

_Plateaux Gastronorme sous la norme européenne EN-631.
_Construit en acier inoxydable.



| | |
|------------|----------------|
| NOR1/1-40 | 530X325X40 mm |
| NOR1/1-100 | 530x325x100 mm |
| NOR1/1-200 | 530x325x200 mm |
| NOR2/1-40 | 646x530x40 mm |
| NOR2/1-100 | 646x530x100 mm |
| NOR2/1-200 | 646x530x200 mm |

Papeleras

_Fabricadas en acero inoxidable.
_Sistema de accionamiento por pedal.
_Cubo interior de plástico extraíble.
_Capacidad de 5, 12, 20, 30 litros.

WASTE bins

_Made in stainless steel.
_Lid operated by pedal.
_Removable plastic bucket inside.
_Capacity 5, 12, 20, 30 liters.

Seau à DÉCHETS

_Fabrication en acier inoxydable.
_Pédale de commande d'ouverture à pied.
_Cuvette intérieur en plastique à poignée.
_Capacity 5, 12, 20, 30 litres.



M076-B



| | | |
|--------|----------------|------|
| M076-B | 295x255x300 mm | 5 l |
| M076-C | 325x260x410 mm | 12 l |
| M076-D | 350x310x470 mm | 20 l |

auxiliar

auxiliary
auxiliar

cubetas de acero inox. / buckets steel stainless / seaux acier inoxydable
papeleras / waste bins / seaux à déchets
cubos / cube / cube

Cubos inox.

- _Fabricados en acero inoxidable.
- _Fondo embutido con radio sanitario.
- _Capacidad 50 y 95 litros.
- _Con ruedas \varnothing 50 mm.
- _Modelos con o sin pedal

Stainless steel BUCKET

- _Manufactured in stainless steel.
- _Capacity: 50 or 95 l.
- _Base with castors \varnothing .
- _With or without pedal.

SEAU d'acier inoxydable

- _Construit en acier inoxydable.
- _Capacité: 50 ou 95 L.
- _Base avec des roulettes \varnothing 50 mm.
- _Avec ou sans pédale.

M077E-50



M077F-90



REF



L

| | | |
|----------|--------------------------|------|
| M077E-50 | \varnothing 380x605 mm | 50 l |
| M077E-90 | \varnothing 450x685 mm | 95 l |
| M077F-50 | \varnothing 380x605 mm | 50 l |
| M077F-90 | \varnothing 450x685 mm | 95 l |

Cubo de QUIRÓFANO

- _Soporte fabricado en acero esmaltado o inoxidable (-I).
- _4 ruedas \varnothing 40mm.
- _Cubeta en acero inoxidable, capacidad 8 ó 12 litros.

WASTE bins

- _Support manufactured in enamelled or stainless steel (-I).
- _4 wheels \varnothing 40mm.
- _Stainless steel basin, capacity 8 or 12 L.

Seau à DÉCHETS

- _Support fabriquée en acier peint ou inoxydable (-I).
- _4 roulettes \varnothing 40mm.
- _Cuvette en acier inoxydable, capacité 8 ou 12 L.

M085-12



M085



M085-A



REF



L

KG

| | | | |
|---------|----------------------|------|------|
| M085 | \varnothing 340 mm | 8 l | 3 kg |
| M085-A | \varnothing 340 mm | 8 l | 3 kg |
| M085-12 | \varnothing 300 mm | 12 l | 3 kg |



almacenaje
storage
stockage

MUEBLES MODULARES ISO 6040

Nuestros muebles ISO 6040 son de alta calidad y resistencia, con gran capacidad de almacenaje. Ofrecemos un amplio catálogo de muebles: altos, bajos, de columnas, cajones o bandejas.

Nuestro compromiso es ofrecer soluciones de almacenaje de calidad a precios competitivos. Nuestra experiencia de más de 25 años en la fabricación de mobiliario clínico nos avala. Hemos ideado una colección dirigida específicamente a instalaciones del sector de la salud.

Our furnitures ISO 6040 have high quality and resistance, with a great storage capacity. We offer a wide range of furnitures: high, low, columns, with shelves, drawers or trays.

Our commitment is too offer quality storage solutions at competitive prices. Our experience of over 25 years in the manufacture of clinical furniture supports us. We have devised a collection directed specifically to health sector.

Nous meubles ISO 6040 sont de haute qualité et résistance, avec grande capacité de stockage. Nous offrons une large gamme de meubles : haut, bas, des colonnes, des tiroirs ou des plateaux .

Notre engagement est d'offrir solutions de stockage de qualité à des prix compétitifs. Notre expérience de plus de 25 ans dans la fabrication de mobilier hospitalier nous soutient. Nous avons conçu une collection visant spécifiquement a les établissements de le secteur santé.



MUEBLES ALTOS DE PARED ISO 6040



Organiza el espacio de una forma clara e intuitiva en nuestros muebles. Gran variedad en accesorios para etiquetar y clasificar los medicamentos.

Organize the space in a clear and intuitive way our furniture. Great variety of accessories to label and classify medicines.

Organise l'espace d'une manière claire et intuitive nos meubles, Grande variété d'accessoires pour étiqueter et classer les médicaments .

ESTANTERÍAS MODULARES



Más información en la página 145 / More information on page 145 / Plus d'informations dans la page 145

ACCESIBILIDAD ■ ORGANIZACIÓN

ACCESSIBILITY / ACCESSIBILITÉ

ORGANISATION



Organiza el espacio de una forma clara e intuitiva con nuestras bandejas y cajetines en nuestros muebles ISO 6040.

Organize the space in a clear and intuitive way with our trays and dispensers in our cabinets ISO 6040.

Organisez l'espace d'une façon claire et intuitive avec nos plateaux dans nos meubles ISO 6040.

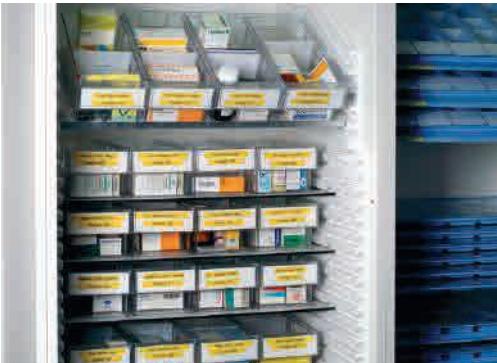

Mantener tu zona o espacio de trabajo organizado puede aumentar la productividad y reducir tu nivel de estrés.

Gracias a nuestros soportes podrás organizar y acceder de forma rápida y sencilla a todos tus materiales de trabajo.

Keep organized your area or workspace organized can increase productivity and reduce your stress level. Thanks our supports you can organize and access quickly and easily all your work materials.

Garder votre région ou espace de travail organisé peut augmenter la productivité et de réduire votre niveau de stress. Merci à nos supports, vous pouvez organiser et accéder rapidement et facilement tous vos matériel de travail.

DISEÑO ■ RESISTENCIA ■ SENCILLEZ

DESIGN / DESSIN

RESISTANCE / RÉSISTANCE

SIMPLICITY / SIMPLICITÉ

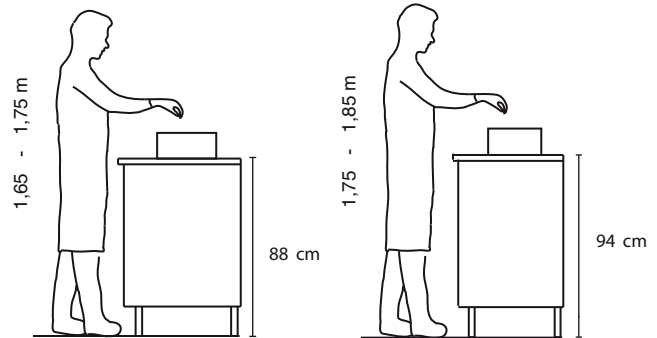

opción *plus*: muebles bajos de 94 cm de altura

option plus: lowers cabinets of 94 cm height

option plus: furnitures bas de 94 cm de hauteur

Disponemos de dos alturas para los muebles bajos, de esta forma nos adaptamos a las distintas necesidades del cliente.

We have two heights for lowers cabinets, thus we adapt our offer to the differents needs.

Nous disposons deux hauteurs pour les meubles bas, de ce façon, nous nous adaptons aux différents besoins des clients.



proyecto 1

project 1 / projet 1

proyecto 2

project 2 / projet 2

proyecto 3

project 3 / projet 3

proyecto 4

project 4 / projet 4

proyecto 5

project 5 / projet 5

proyecto 6

project 6 / projet 6

proyecto 7

project 7 / projet 7

proyecto 8

project 8 / projet 8

proyecto 9

project 9 / projet 9

composiciones

compositions

composición 1 / composition 1
composición 2 / composition 2
composición 3 / composition 3
composición 4 / composition 4



Composición 1. La persiana permite ocultar los objetos almacenados de una forma elegante.

Composition 1. The shutter can hide stored objects in an elegant way.

Composition 1. La persienne peut masquer des objets stockés dans une manière élégante.



Composición 2. Con mueble central alto con cajas basculantes permite tener un rápido acceso a los objetos almacenados.

Composition 2. The central cabinet with tilted boxes allows a quick access to stored objects.

Composition 2. Le furniture central avec les boîtes basculants permettent de avoir les objets stockés.



Composición 3. El escritorio permite combinar el espacio de trabajo con el de oficina.

Composition 3. The desktop allows to combine different work areas.
Composition 3. Le bureau permet de combiner différents espaces de travail.



Composición 4. Combina dos espaciosa áreas de trabajo a dos alturas.

Composition 4. Combine two spacious work areas on two levels.
Composition 4. Combinez deux grands espaces de travail sur deux niveaux.



Composición 5. Gana flexibilidad combinando muebles fijos con muebles móviles.

Composition 5. Gain flexibility by combining fixed and movable cabinets.
Composition 5. Gagnez de la flexibilité en combinant meubles fixes et mobiles.



Composición 6. Módulos especialmente diseñados para pediatría con bañera para bebés.

Composition 6. Modules specially designed for pediatrics with baby bath.
Composition 6. Modules spécialement conçus pour la pédiatrie avec bain de bébé.



Composición 7. Disponen de una superficie que sirve como zona de trabajo y paneles para cestas y bandejas ISO 6040.

Composition 7. They have a working surface and pannels or baskets and trays ISO 6040.

Composition 7. Ils disposent d'une surface qui serve comme zone de travail. Panneaux pour les paniers et plateaux ISO 6040.



Composición 8. Dispone de 5 modulos con paneles para cestas ISO 60/40. Las columnas ocultan los paneles mediante puertas abatibles en la parte baja y persianas en la parte alta.

Composition 8. It has 5 modules with panels for baskets ISO 60/40. The columns hide the panels by folding doors at the bottom and shutters at the top.

Composition 8. Il dispose de 5 modules avec des panneaux paniers ISO 60/40. Les colonnes cachent les panneaux par des portes pliantes en bas et les persiennes au sommet.



Composición 9. Conformada por 8 módulos de 65 cm de ancho. Ofrece gran capacidad de almacenamiento. Dispone de un soporte central de acero inoxidable que permite tener objetos al alcance de la mano.

Composition 9. Conformed by 8 modules of 65 cm wide. It offers great capacity. It has a central stainless steel support that allows to reach the objects easily.

Composition 9. Conformé par 8 modules de 65 cm de largeur. Il offre une grande capacité de storage. Il dispose d'un support central d'acier inoxydable qui permet d'avoir les objets plus prochains.



bajos

base / bas

altos

wall mounted / murals

columnas

columns / colonnes

opción *plus*: muebles bajos de 94 cm de altura



REF
M326

REF
M326-C

Muebles bajos de 1 puerta abatible, disponibles con cristal.
Base cabinet with 1 door, available with glass door.
Meuble bas 1 porte, disponible porte vitrée.

REF



M326
M326-C

45x60x85 cm
45x60x85 cm



REF
M327

REF
M327-C

Muebles bajos de 2 puertas abatibles, disponibles con cristal.
Base cabinet with 2 doors, available with 2 glass doors.
Meuble bas 2 portes, disponible porte vitrée.

REF



M327
M328
M327-C
M328-C

65x60x85 cm
90x60x85 cm
65x60x85 cm
90x60x85 cm



Bisagras especiales que permiten un aprovechamiento total del interior del mueble.

Special hinges that allow total use of the interior of the cabinet.
Charnières spéciales qui permettent la pleine utilisation de l'intérieur du meuble.



Muebles bajos con puerta abatible y cajón.
Base cabinet with 1 door and 1 drawer.
Meuble bas avec 1 porte et un tiroir.

REF



M329

45x60x85 cm

los muebles

bajos / base / bas
altos / wall mounted / muraux
columnas / high / hauts



Mueble 2 puertas y un cajón.

Base cabinet 2 doors and 1 drawer.

Meuble 2 portes and 1 tiroir.



M330



65x60x85 cm



Mueble bajo con 5 cajones pequeños.

Base cabinet 5 little drawers.

Meuble bas 5 petits tiroirs.



M331

M332

M333



45x60x85 cm

65x60x85 cm

90x60x85 cm



Mueble 3 cajones pequeños y 1 mediano.

Base cabinet 3 little drawers and 1 medium-sized.

Meuble bas 3 petits tiroirs and 1 moyen.



M334

M335

M336



45x60x85 cm

65x60x85 cm

90x60x85 cm



Mueble con 2 cajones medianos y 1 pequeño.

Base cabinet 2 medium-sized drawers and 1 little.

Meuble bas 2 tiroirs moyens and 1 petit.



M337

M338

M339



45x60x85 cm

65x60x85 cm

90x60x85 cm



Mueble bajo con puerta extraíble.

Base cabinet with 1 pull-out door.

Meuble bas 1 porte coulissant.



M340



45x60x85 cm

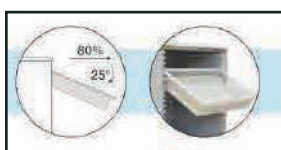
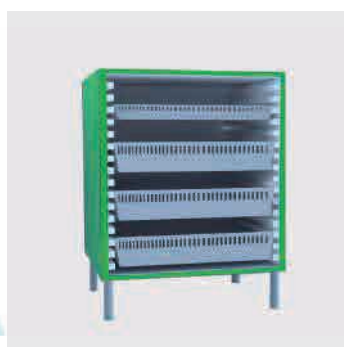

Mueble bajo abierto con paneles ISO 6040.

Opened base cabinet with panels ISO 6040 .

Meuble bas ouvert avec panneaux ISO 6040.



M325

M324



45x60x85 cm

65x60x85 cm



Mueble con fregadero. Diferentes tipos de grifos, para mayor información consultar la pagina 138.

Base cabinet for sink. Diferents water taps availables, for more information, please consult page 138.

Meuble bas avec évier. 3 types de robinet differents, disponible sur la page 138.



M341
M342



45x60x85 cm
65x60x85 cm



Fregadero de acero inox. Medidas: 338x368x155 mm para mueble de 45cm.

Sink in stainless steel. Dimensions: 338x368x155 mm for cabinet 45 cm.

Basin en acier inoxydable. Dimensions: 338x368x155 mm pour mouble 45 cm.

Modelo de fregadero incluido.

Model sink included.

Modèle évier inclus.



Mueble con bañera para bebé. Disponible con 3 grifos diferentes, consulte en la página 137.

Base cabinet with baby bath. Available with 3 different taps, for more information, at page 137.

Meuble bas avec baignoire pour bébé. Disponible avec 3 robinets différents, consultez la page 137.



M343



90x60x85 cm



Bañera para bebé de acero inoxidable.

Baby bath in stainless steel.

Baignoire pour acier inoxydable.



M370



915x550x150 mm

los muebles

cabinets / meubles

bajos / base / bas
altos / wall mounted / muraux
columnas / high / hauts



Grifo mezclador, palanca para codo.

Mixer tap elbow operated.
Robinet à coudé mélangeur.



M481



Grifo mezclador con caño alto.

Mixer tap high spout.
Robinet mélangeur de bec haut.



M488



Grifo mezclador con caño extraíble.

Mixer tap with removable spout.
Robinet mélangeur avec bec amovible.



M489



Mueble bajo con apertura para papelerera.

Base cabinet with opening for paper bin.
Meuble bas avec aperture pour poubelle.



M350



60x60x85 cm

los muebles

cabinets / meubles

baja / base / bas
altos / wall mounted / muraux
columnas / high / hauts

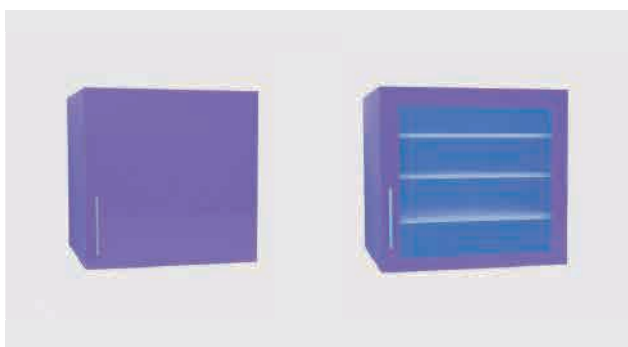

REF
M351

REF
M351-C

Muebles altos de 1 puerta abatible, disponibles con cristal.
Wall mounted cabinets with 1 door, available with glass door.
Meubles muraux avec 1 porte, disponible avec porte vitrée.



M351
M351-C



45x35x60 cm
45x35x60 cm

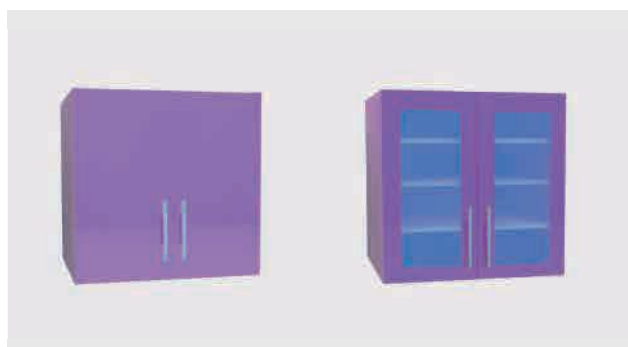

REF
M353

REF
M353-C

Muebles altos de 2 puerta abatible, disponibles con cristal.
Wall mounted cabinets with 2 doors, available with glass doors.
Meubles muraux avec 2 portes, disponible avec portes vitrées.



M353
M354
M353-C
M354-C



45x35x60 cm
65x35x60 cm
45x35x60 cm
65x35x60 cm

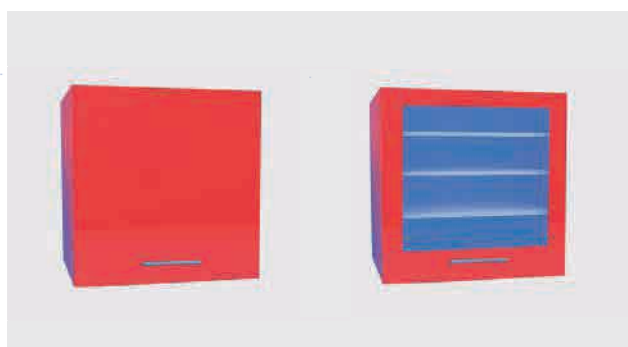

REF
M355

REF
M355-C

Muebles altos de 1 puerta horizontal, disponibles con cristal.
Wall mounted cabinets with 1 horizontal door, available with glass door.
Meubles muraux avec 1 porte horizontal, disponible avec porte vitrée.



M355
M356
M355-C
M356-C



45x35x60 cm
65x35x60 cm
45x35x60 cm
65x35x60 cm



Mueble alto con persiana.
Wall mounted cabinet with shutter.
Meubles muraux avec persienne.



M357
M358



60x35x60 cm
90x35x60 cm



Mueble alto abierto.
Wall mounted opened cabinets.
Meuble mural ouverts.

| | |
|------|-------------|
| REF | ↔ ↗ ↑ |
| M358 | 45x35x60 cm |
| M359 | 65x35x60 cm |
| M360 | 90x35x60 cm |



Mueble con cajas basculantes.
Furniture with tilted dispensers.

Muebles avec distributeur incliné.

| | |
|------|-------------|
| REF | ↔ ↗ ↑ |
| M362 | 65x35x60 cm |



Mueble tipo columna con puertas abatibles en la parte baja y persiana en la parte superior. Con estante intermedio a la altura de la encimera.

Column cabinet with 2 lower doors and upper shutter.
Meuble colonnes avec 2 portes inférieures et 1 persienne supérieure.

| | |
|------|--------------|
| REF | ↔ ↗ ↑ |
| M364 | 65x60x170 cm |
| M365 | 65x60x200 cm |



Mueble columna abierto con paneles ISO 60/40

Column opened cabinet with ISO 6040 panels.
Meuble colonne ouvert avec panneaux ISO 6040.

| | |
|------|--------------|
| REF | ↔ ↗ ↑ |
| M366 | 65x60x170 cm |
| M367 | 65x60x200 cm |



Mueble columna con 4 puertas. Paneles ISO 6040 en la parte baja y estantes en la parte superior.

Column cabinet with 4 doors. ISO 6040 panels at the bottom and 5 shelves at the upper part.

Meuble colonne avec 4 portes. Panneaux ISO 6040 dans la part supérieure et 5 étagères dans l'inférieure.

| | |
|------|--------------|
| REF | ↔ ↗ ↑ |
| M368 | 65x60x170 cm |
| M369 | 65x60x200 cm |

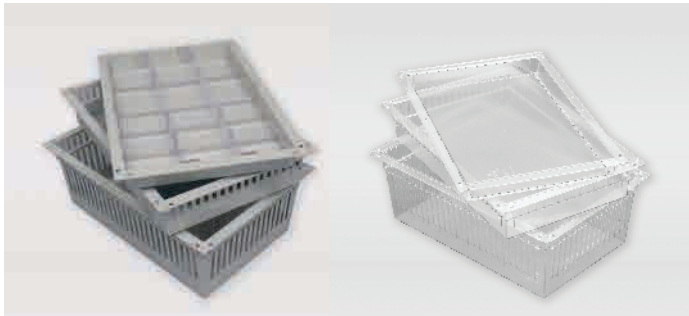

Cestas ISO 6040 ABS o policarbonato transparente (+T)
ISO 6040 modular tray. ABS or polycarbonate (+T).
Paniers ISO 6040 modulaire. ABS or Polycarbonate
Transparent (+T).



C015
C050
C100
C200



600x400x15 mm
600x400x50 mm
600x400x100 mm
600x400x200 mm

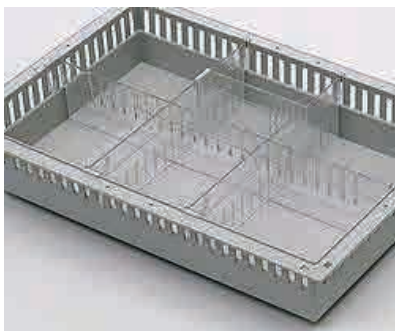

Separadores con click lateral para cestas ISO.
Dividers for ISO modulars trays.
Séparateur pour paniers ISO 6040.



OP888-50-600
OP888-50-400
OP888-100-600
OP888-100-400
OP888-200-400
OP888-200-600



600x50 mm
400x50 mm
600x100 mm
400x100 mm
400x200 mm
600x200 mm



Bandeja de medicación
semanal.

Weekly medication trays.
Plateau medication
hebdomadaire.



MB4000E



407x245 mm



Pregunte por otras
bandejas de medicación

Ask for more medication
trays.

Consultez sur autres
plateaux de medication.

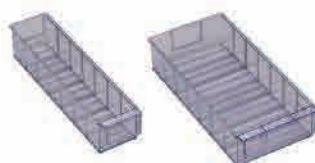

Cajetines transparentes.

Transparents boxes.
Boîtes transparentes.



CS091
CS183



91x300x81 mm
183x300x81 mm



Porta etiquetas.

Label holder.

Porte étiquettes.



OP888-29

ALMACENAMIENTO MODULAR PARA SISTEMA ISO 6040.



Utilizar el sistema de estanterías modulares permite un almacenamiento seguro, óptimo y de alta calidad, además de la posibilidad de ampliación por módulos según sus necesidades y la combinación con numerosos accesorios, tales como ISO- módulos, estantes, cestas, ruedas, guías...

MODULAR STORAGE SYSTEM ISO 6040 .

Use modular shelving system allows secure, optimum and high quality storage and the possibility of extension by modules according to their needs and the combination with numerous accessories such as ISO modules, shelves, baskets, wheels, guides..

STOCKAGE MODULAIRE SYSTÈME ISO 6040 .

En utilisant le système de rayonnage modulaire permet un stockage sécurisé optimal et de haute qualité aussi la possibilité d'extension par des modules en fonction de leurs besoins et la combinaison avec de nombreux accessoires tels que les modules ISO, des étagères, des paniers, roues, guides...





**muebles
inox**

steel furniture
meubles inox

Estanterías DE ALUMINIO Y POLIETILENO

MLA-1

- _Estructura en aluminio anodizado y estantes de polietileno alimentario.
- _Estantes con doble apoyo.
- _Gran capacidad de carga.
- _Posibilidad de incorporar ruedas, montaje en ángulo.
- _Consultar medidas disponibles.

ALUMINUM AND POLYETHYLENE shelves

- _Anodized aluminum structure and polyethylene food shelves.
- _Double support shelves.
- _High load capacity.
- _Possibility of incorporating wheels, mounting angle.
- _Consult available measures.



Étagères de ALUMINIUM ET POLYÉTHYLÈNE

- _Structure en aluminium anodisé et les étagères alimentaires en polyéthylène.
- _Étagères doubles de soutien.
- _Grande capacité de charge.
- _Possibilité d'incorporer des roues, angle de montage.
- _Consultez mesures disponibles.



Estantes extraíbles pudiéndose lavar en lavavajillas.

Removable shelves. They can be washed in a dishwasher.
Étagères amovibles. Ils peuvent être lavés dans un lave-vaisselle.



De muy fácil montaje, sin ningún tipo de herramienta.

Very easy to assemble without any tools.
Très facile à monter sans outils.



Soportes con orificios cada 150 mm para poder regular o incrementar el número de estantes.

Supports with holes every 150 mm to increase the number of shelves.
Supports avec des orifices chaque 150 mm pour pouvoir réguler ou augmenter le nombre d'étagères.

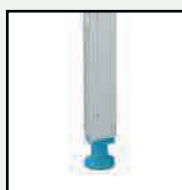

Soportes con pies de altura regulable 40 mm.

Supports with height-adjustable feet 40 mm.
Support avec les pieds réglables en hauteur.

muebles inox.

furnitures in stainless steel
meubles en a. inox

estanterías/ shelves / étagères

mesas de trabajo / work table / tables de travail

mueble cerrado / closed cabinet / meuble fermé

Estanterías y carros MODULARES DE ACERO INOXIDABLE

_ Estantería modular concebida para su instalación por módulos en cualquier ambiente, permite intercalar estantes, crecimiento longitudinal y ángulo recto, conservando los mismos planos horizontales.

_ Fabricado en acero inoxidable AISI 304.

_ Cantos redondeados libre de aristas y zona de corte.

_ Sistema abrazaderas sin tornillos.

_ Gran resistencia de carga (60 kg por estante).

_ Libre de orificios y tornillos, los que evita la acumulación de suciedad.

MODULAR Trolleys and Shelves IN STAINLESS STEEL

_ Designed for module installation in all types of settings. It is possible to insert shelves, extend them length-wise and in straight angles.

_ Made of stainless steel AISI 304.

_ Rounded edges.

_ Easy assembly, bracing system (without screws).

_ High resistance (60 kg per shelf).

_ System of assembly with clips, without holes and screws, that prevents accumulation of dirt.

Étagères et chariots MODULAIRES EN ACIER INOXYDABLE

_ Étagères modulaires, conçues pour leur installation par modules dans n'importe quel milieu environnant. Permettent d'intercaler des rayons, croissance longitudinale et angle droit.

_ Fabriqué en acier inox AISI 304.

_ Sans arêtes et bords arrondis.

_ Système de serrage sans vis.

_ Grande résistance de charge (60 kg par tablette).

_ Pas de trous ou de vis, ce qui empêche l'accumulation de saleté.



Sistema de montaje a base de abrazaderas sin tornillos.

System of mounting with out screwss.

Système de montage avec pinze sans vis.



Fabricado en acero inox 18/8, tubo de 28 mm.

Manufactures in stainless steel 18/8, tube 28 mm.

Fabriqué acier inoxydable 18/8, tube 28 mm.



Regulable cada 50 mm. Cantos redondeados libres de aristas.

Adjustable every 50 mm. Rounded edges.

Réglable chaque 50 mm. Bords arrondis.

muebles inox.

furniture in stainless steel
meubles en a. inox

estanterías/ shelves / étagères

mesas de trabajo / work table / tables de travail

mueble cerrado / closed cabinet / meuble fermé

MEDIDAS ESTANTES Y POSTES.

| Ancho ESTANTE | Alto POSTE |
|---|-----------------|
| 45 cm | 50 cm |
| | 75 cm |
| | 100 cm |
| | 150 cm |
| | 175 cm |
| | 200 cm |
|  | Largo |
| | 75 cm 100 cm |

VARIAS POSIBILIDADES DE CONFIGURACIÓN.



TIPOS DE ESTANTES.



Estante liso.
Smooth shelf.
Étagère lisse.



Parrilla.
Grilled.
Griller.



Cesta.
Basket.
Paniers.

ACCESORIOS.



Rueda grande.
Big wheel.
Grande roue



Rueda pequeña.
Small wheel.
Petite roue.



Soporte pared.
Wall support.
Support mural.



Detalle continuidad.
Detail continuity.
Détail continuité.

Mesas de trabajo

- _Fabricadas en acero inoxidable.
- _Con omegas de refuerzo y acabado satinado.
- _Patas de tubo de 40x40 con niveladores.
- _Varias medidas disponibles.
- _Modelos: centrales (-C), murales (-P), con fregadero, industriales (-PFG).
- _Estructuras desmontables para facilitar su transporte y almacenaje.
- _Opcional: estante inferior.

Work table

- _Manufactured in stainless steel.
- _Satin finished.
- _Legs in square tube 40x40 with leveling.
- _Available several dimensions.
- _Models: with (-P) or without (-C) skirting board, with basin (-PF).
- _Detachable structures to facilitate its transport and storage.
- _Option: lower shelf.

Tables de travail

- _Fabriquée en acier inoxydable.
- _Satin fini.
- _Jambes dans le tube carré 40x40 avec niveleur.
- _Disponible plusieurs dimensions
- _Modèles: sans dossier (-C) pour zone centrale, avec dossier (-P), avec évier (-PF).
- _Structures détachables pour faciliter son transport et stockage.
- _À choisir: étagère inférieure.

M0105CE



M0105PE



M0105PEF



M0105PFG



M0105PFH



REF



| | |
|-----------|-----------------|
| M0105CE | 1200x600x850 mm |
| M0105PE | 1200x600x850 mm |
| M0105PEF | 1200x600x850 mm |
| M0105PFG | 1200x600x850 mm |
| M01014FFH | 1400x600x850 mm |

muebles inox.

furnitures in stainless steel
meubles en a. inox

mesas de trabajo / work table / tables de travail
mueble cerrado / closed cabinet / meuble fermé
lavabos / whasbasins / lavabos

Mueble CERRADO

MLA701

- _Fabricado en acero inoxidable.
- _Encimera con omegas de refuerzo. Peto posterior.
- _Estante interior.
- _Puertas correderas.
- _Patas robustas redondas de 150 mm de altura.
- _Disponible modelo con fregadero con cajonera.

CLOSED cabinet

- _Manufactured in stainless steel.
- _Worktop with skirting board.
- _Inner shelf.
- _Adjustable 150 mm legs.
- _Sliding doors.
- _Available: module with 3 drawers, with basins.

Meuble FERMÉ

- _Construite en acier inoxydable.
- _Avec dossier.
- _Etagère en hauteur.
- _Pieds de 150 mm réglables.
- _Portes coulissantes suspendues.
- _Disponible: modele avec 3 tiroirs, avec évier.



MLA702



MLA701/1F



| | |
|-----------|-----------------|
| MLA701/1 | 1000x600x850 mm |
| MLA701/2 | 1200x600x850 mm |
| MLA701/3 | 1600x600x850 mm |
| MLA702/1 | 1400x600x850 mm |
| MLA702/2 | 1600x600x850 mm |
| MLA702/3 | 1800x600x850 mm |
| MLA701/1F | 1400x600x850 mm |

Lavabos MEDICAL

M475

- _Fabricado en acero inoxidable AISI 304 18/10.
- _Sistema de enganche a la pared.
- _Modelos de 1 (M474), 2 (M475) y 3 (M476) plazas.
- _Con peto trasero.

🇬🇧 MEDICAL washbasins

- _Manufactured in stainless steel AISI 304 18/10.
- _Wall holder system.
- _Models 1 (M474), 2 (M475) or 3 (M476) places.
- _With skirting board.

🇫🇷 Lavabos MEDICAL

- _Construit en acier inoxydable AISI 304 18/10.
- _Possibilité d'accrochage au mur.
- _Avec dossier modélé 1 (M474), 2 (M475) ou 3 (M476) places.



| REF | ↔ ↑ ↻ | KG |
|------|-----------------|-------|
| M474 | 750x520x470 mm | 12 kg |
| M475 | 1500x520x470 mm | 22 kg |
| M476 | 2000x520x470 mm | 32 kg |



Grifo mezclador Medical de pared
Medical mixer tap, wall mounted
Robinet mélangeur Medical murale

REF M478



Grifo mezclador palanca para codo.
Lever mixer tap elbow.
Robinet à coudé mélangeur

REF M481



Grifo monomando clínico
Clinical water tap
Robinet monocommande clinique

REF M479



Grifo pedal
Pedal tap
Robinet avec pedal

REF M484



Grifo monomando caño alto.
Mixer tap high spout.
Robinet monocommande de bec haut

REF M488



Grifo mezclador con caño extraíble.
Mixer tap with removable spout.
Robinet mélangeur bec amovible

REF M489



Grifo infrarrojo
Infrared tap
Robinet infrarouge

REF M480

Lavamanos MURAL

MCT0138

- _Fabricados en acero inoxidable.
- _Cubeta redonda ø 260 x 100 mm.
- _Grifo caño giratorio y pulsador temporizado.
- _Mezclador dos aguas.
- _Dispone de dosificador de jabón.

🇬🇧 Washbasins

- _Manufactured in stainless steel.
- _Basin ø 260 x 100 mm.
- _Mixing tap with button.
- _With soap dispenser.

🇫🇷 Lave-mains

- _Fabriqué en acier inoxydable.
- _Évier ø 260 x 100 mm.
- _Robinet et bouton.
- _Avec distributeur de savon.



MCT0138

400x400x173 mm

15 kg

Lavamanos PEDAL

M470

- _Construido en acero inoxidable.
- _Cubeta ø360 x 130 mm.
- _Grifo caño giratorio y pulsador de pie.
- _Dosificador de jabón opcional.
- _Puerta frontal registrable.
- _Se suministran totalmente equipados.

🇬🇧 FOOT-PEDAL Washbasins

- _Manufactured in stainless steel.
- _Basin ø 360 x 130 mm.
- _Mixing tap, pedal operated.
- _Soap dispenser optional.
- _Front door.

🇫🇷 Lave-mains avec PÉDALE

- _Fabriqué en acier inoxydable.
- _Évier ø 360 x 130 mm.
- _Robinet avec pédale.
- _Distributeur de savon a cloisir.
- _Porte avant.

Opcional



M470

400x440x850 mm

30 kg

Mueble lavabo PARITORIO

M560

- _Fabricado en acero inoxidable AISI 304 18/10.
- _Bañera para bebe y zona de trabajo.
- _Armario inferior con puertas correderas.
- _Opción: colchoneta (M560-CO).

BABY Bathtub

- _Manufactured stainless steel AISI 304 18/10.
- _Bathtub for baby and working area.
- _Lower cupboard with sliding doors.
- _Option: mattress.

Bain pour NOUVEAU-NÉ

- _Construit en acier inoxydable.
- _Bain pour nouveau-né et plan de travail.
- _Cabinet inférieur avec portes coulissantes.
- _À choisir: matelas (M560-CO).



| REF |    | KG |
|---------|---|-------|
| M560 | 1500x550x850 mm | 60 kg |
| M560-CO | 690x490x40 mm | |

Puesto de ENFERMERÍA

M555

- _Fabricado en acero inoxidable AISI 304 18/10.
- _Parte superior: Negatoscopio de 1 pantalla. Vitrina de puertas correderas con dos estantes de cristal.
- _Parte inferior: Un seno y zona de trabajo. Armario inferior con tres puertas y un estante. Incluye grifo mezclador monomando. Posibilidad de adquirir solo parte inferior (-B).



NURSE Control

- _Manufactured in stainless steel AISI 304 18/10.
- _Upper part: Negatoscope single. Cabinet with sliding doors and two inner shelves.
- _Lower part: One sink and working area. Lower cupboard with three doors and inner shelf. Includes mixer tap.
- _Possibility of purchasing just the lower part (-B)

Armoire pour CONSULTATIONS

- _Construit en acier inoxydable AISI 304 18/10.
- _Partie supérieure: Negatoscope un écran. Armoire avec portes coulissantes et deux étagères.
- _Partie inférieure: Avec bassin. Robinet. Cabinet inférieur avec 3 portes et étagère.
- _Possibilité d'acheter seulement la partie inférieure (-B).



| REF |    |
|------|---|
| M555 | 1500x550x2000 mm |
| M556 | 1350x550x2000 mm |

Ventana QUIRÓFANO

- _Fabricado acero inoxidable AISI 304 18/8
- _Ventana de metacrilato con asidero. (Posibilidad de fabricarla en acero inoxidable)
- _Sistema de contrapeso de movimientos verticales.
- _Se fabrican en dos anchos para adaptarse a distintos tipos de pared.

🇬🇧 Operating room WINDOW

- _Made of stainless steel AISI 304 18/8
- _Methacrylate window, with handle. (Possibility to manufacture in stainless steel)
- _Counterweight system of vertical movements.
- _Two available widths to adapt to different types of wall.

🇫🇷 FENÊTRE Pour salle d'opération

- _Fabriqué en acier inox AISI 304 18/8
- _Fenêtre en méthacrylate, avec poignée. (Possibilité de fabriquer l'acier inoxydable)
- _Système de contreponds des mouvements verticaux.
- _Ils sont fabriqués en deux largeurs pour s'adapter à différents types de mur.

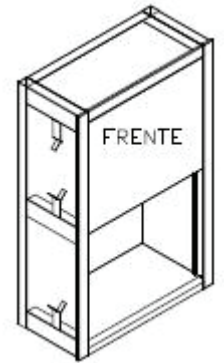

M491



M491

770x1230 mm

16 kg

Lavacuñas

- _Construido en acero inoxidable.
- _Para cuñas de tamaño estándar.
- _Grifos de agua fría y caliente, disponible temporizador.
- _Para empotrar en la pared o colocar en superficie.

🇬🇧 BED PAN Steriliser

- _Manufactured in stainless steel.
- _Standard bedpans.
- _Taps for cold and hot water.
- _Wall mounted or built in the wall.

🇫🇷 Stérilisateur pour BASSINS de lit

- _Construit en acier inoxydable.
- _Dessiné pour bassins de dimensions standard.
- _Robinet pour eau chaude et froide.
- _Pour placé sur mur ou sur la surface.



M496



M496

480x820 mm

18 kg

M496-S

480x820 mm

18 kg

Armario DE PIE

MLA801-1

- _Construidos en acero inoxidable AISI 304 18/10.
- _Tres estantes intermedios con omegas de refuerzo.
- _Gran capacidad (hasta 80 kg por estante).
- _Puertas practicables.
- _Patas de 150 mm regulables.
- _Cerradura con llave.

STANDING Cabinet

- _Manufactured in stainless steel AISI 304 18/10.
- _3 shelves with reinforcement.
- _Great capacity (80 kg per shelf).
- _Practicable doors.
- _Adjustable legs of 150mm.
- _Lock with key.

Armoire DEBUT

- _Fabriqué en acier inoxydable AISI 304 18/10.
- _3 étagères intermédiaires avec des omégas de support.
- _Grande capacité, (80 kg par étagère).
- _Portes praticables avec fermeture.
- _Jambes de 150 réglable.



| | |
|----------|------------------|
| MLA801-1 | 1000x600x1900 mm |
| MLA801-2 | 1200x600x1900 mm |
| MLA801-3 | 1400x600x1900 mm |

Armario MURAL inox.

MLA803-1

- _Fabricado totalmente en acero inoxidable.
- _Puertas correderas con sistema de rodamientos.
- _Estante intermedio, regulable en altura.
- _Anclaje a pared.

WALL cabinet in stainless steel

- _Manufactured in stainless steel.
- _Sliding doors.
- _Inner shelf.
- _Wall fixation.

Armoire MURALE en acier inoxydable

- _Fabriquée en acier inoxydable.
- _Portes coulissantes de double paroi.
- _Étagère intermédiaire.
- _Murale.



| | |
|----------|-----------------|
| MLA803-1 | 1000x400x600 mm |
| MLA803-2 | 1200x400x600 mm |
| MLA803-3 | 1400x400x600 mm |

muebles inox.

furnitures in stainless steel
meubles en a. inox

armario de limpieza / cleaning closet / cabinet de nettoyage
armarios altos / cupboard higher / placards supérieur

Armario DE LIMPIEZA

- _Fabricado en acero inoxidable AISI 304 18/10.
- _3 estantes.
- _Cerradura con llave.
- _Patas de 150 mm.

CLEANING cabinet

- _Manufacture in stainless steel AISI 304 18/10.
- _3 étagères
- _Lock with key.
- _Legs 150 mm.

Cabinet de NETTOYAGE

- _Fabriqué en acier inoxydable AISI 304 18/10.
- _3 shelves.
- _Porte à fermeture.
- _Jambas 150 mm.

MLA802-2

MLA802-1



| | |
|----------|------------------|
| MLA802-1 | 1000x450x1900 mm |
| MLA802-2 | 600x450x1900 mm |

Armarios ALTOS

- _Fabricado en acero inoxidable AISI 304 18/10.
- _3 estantes intermedios con omegas de refuerzo.
- _Carga máxima por estante: 80 kg.
- _Puertas correderas.
- _Cerradura con llave
- _Patas 150 mm regulables.

CUPBOARDS higher

- _Manufactured in stainless AISI 304 18/10.
- _3 inner shelves.
- _Capacity: 80 kg per shelf.
- _Sliding doors.
- _Lock with key.
- _Adjustable legs 150 mm.

PLACARDS supérieur

- _Fabriqué en acier inoxydable AISI 304 18/10.
- _3 étagères.
- _Capacité: 80 kg par étagère.
- _Portes coulissants.
- _Bloquer avec clés.
- _Lambes de 150 réglable.



| | |
|----------|------------------|
| MLA804-1 | 1200x600x1900mm |
| MLA804-2 | 1600x600x1900 mm |

MLA804



muebles inox.

furnitures in stainless steel
meubles en a. inox

armarios altos / cupboard higher / placards supérieur
dispensadores /dispensers / dispensers
soportes para cuñas y botellas / supports for bedpan and bottles /
supports pour bassins de lit et bouteilles

Dispensadores

- _Fabricados en acero inoxidable AISI 304 18/10.
- _Para cepillos (FM00110), zapatillas (FM00108) o gorros (FM00111).
- _Fabricación a medida. Consultar.

DISPENSERS

- _Manufactured in stainless steel AISI 304 18/10.
- _For chirurgical brushes (FM00110), slippers (FM00108) or caps (FM00111).
- _Manufactured made to measure. Consult.

DISPENSERS

- _Fabriqué en acier inoxydable AISI 304 18/10.
- _Pour brosses (FM00110), couvre chaussures (FM00108) et coiffes chirurgical (FM00111).
- _Fabrication sur mesure. Consultez.

REF

FM00108
FM00110
FM00111

FM00108



FM00110



FM00111



Soportes para cuñas y botellas

- _Fabricados en acero inoxidable AISI 304 18/10.
- _Varias configuraciones disponibles.

SUPPORTS FOR BEDPAN AND BOTTLES

- _Made of stainless steel AISI 304 18/10.
- _Several models.

SUPPORTS POUR BASSINS DE LIT ET BOUTEILLES

- _Fabriqué en acier inoxydable AISI 304 18/10.
- _Différentes configurations disponibles.



REF

MJS002 SOPORTE PARA 2 CUÑAS
FM00024 SOPORTE PARA CUÑA Y BOTELLA
FM00025 SOPORTE PARA PALANGANA, CUÑA Y BOTELLA

muebles inox.

furnitures in stainless steel
meubles en a. inox

dispensadores /dispensers / dispensers
soportes para cuñas y botellas / supports for bedpan and bottles / supports pour bassins de lit et bouteilles
fabricación especial / special manufacturing / fabrication spéciale

Fabricación especial muebles.

SPECIAL MANUFACTURING FURNITURE.
FABRICATION SPÉCIALE MEUBLES.



Exposición de algunos muebles / Exhibition of some furniture / L'exposition de certains meubles



Si desea ampliar información relacionada con muebles inox. especial, por favor consúltenos.

For any questions regarding steel special furniture, please contact us.

Pour toute question concernant les meubles en acier spécial, s'il vous plaît contactez-nous.

muebles inox.
furniture in stainless steel
meubles en a. inox

dispensadores /dispensers / dispensers
soportes para cuñas y botellas / supports for bedpan and bottles /
supports pour bassins de lit et bouteilles
fabricación especial / special manufacturing / fabrication spéciale

Fabricación especial carros, estanterías, soportes y camillas

SPECIAL MANUFACTURING TROLLEYS, SHELVES, SUPPORTS AND EXAMINATION TABLES.
FABRICATION SPÉCIALE CHARIOTS, TABLETTES, SUPPORTS ET TABLE D'EXAMEN.



Exposición de algunos / Exhibition of some / L'exposition de certains.



Si desea ampliar información relacionada con muebles inox. especial, por favor consúltenos.

For any questions regarding steel special furniture, please contact us.

Pour toute question concernant les meubles en acier spécial, s'il vous plaît contactez-nous.

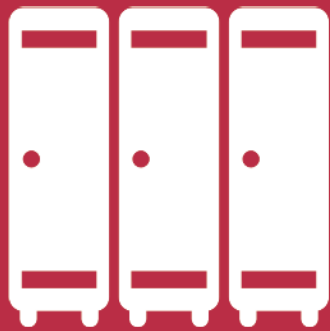

colectividades
collectivities
collectivités

colectividades

colectivities
colectivités

taquillas / lockers / casiers
cabinas / cabins / cabines
bancos / benches / banques

Taquillas

SERIE M605

- _Fabricadas en acero pintado.
- _Puertas con etiquetero y roseta de ventilación.
- _Sistema de inicial y extensiones.
- _Sello montaje, sin tornillos ni herramientas.
- _Modular, ampliable a voluntad.
- _Cerradura de cilindro cromada, con llave.
- _De 1, 2, 3 y 4 puertas.
- _Disponible en varios anchos.

🇬🇧 LOCKERS

- _Manufactured in enamelled steel.
- _Doors with labeler and rosette ventilation.
- _Initial system and extensions.
- _Easy to put on, no screws, no tools.
- _Voluntary extensions.
- _Cylinder chromed lock with key.
- _1, 2, 3 or 4 doors.
- _Available in different widths.

🇫🇷 CASIERS

- _Fabriquée en acier peint.
- _Portes avec étiqueteur et rosettes de ventilation.
- _Système initiale et extensions.
- _Assemblage simple, sans vis ni outil.
- _Extensible à volonté.
- _Serrure de cylindre chromée avec key.
- _1, 2, 3 et 4 portes.
- _Disponible en plusieurs largeurs.



ACCESORIOS / ACCESSORIES / ACCESOIRES



REF



MOD

| | | |
|-------------|-----------------|--|
| M605-1I-250 | 280x510x1800 mm | 1 puerta inicial / 1 initial door / 1 porte initiale |
| M605-2I-250 | 280x510x1800 mm | 2 puerta inicial / 2 initial doors / 2 portes initiale |
| M605-3I-250 | 280x510x1800 mm | 3 puerta inicial / 3 initial doors / 3 portes initiale |
| M605-4I-250 | 280x510x1800 mm | 4 puerta inicial / 4 initial door / 4 porte initiale |
| M605-1-250 | 380x510x1800 mm | 1 puerta inicial / 1 initial door / 1 porte initial |
| M605-2-350 | 380x510x1800 mm | 2 puerta inicial / 2 initial doors / 2 portes initial |
| M605-3-250 | 380x510x1800 mm | 3 puerta inicial / 3 initial doors / 3 portes initial |
| M605-4-350 | 380x510x1800 mm | 4 puerta inicial / 4 initial doors / 4 portes initial |

colectividades

colectivites
colectivités

taquillas / lockers / casiers
cabinas / cabins / cabines
bancos / benches / bancs

Cabinas FENÓLICAS

M608

- _Taquillas fabricadas en tablero compacto de resinas fenólicas. 10 y 12 mm de espesor.
- _Recomendado para ambientes húmedos. Resistente al agua.
- _Fácil montaje.
- _Pata regulable en altura.
- _Tornillería y bisagras en acero inoxidable.
- _Material de gran resistencia, hidrófugo, ignífugo y antibacteriano
- _Fácil limpieza

PHENOLIC Cabins

- _Manufactured with compact panels made of phenolic resins. 10 y 12 mm thickness.
- _Recommended for wet areas. Waterproof.
- _Easy assembly.
- _Legs adjustable in height.
- _Screws and hinges in stainless steel.
- _Material of great resistance, hydrophobic, fire resistant and antibacterial.
- _Easy cleaning.

Cabines PHÉNOLIQUES

- _Vestiaires fabriqués en stratifié compact.
- _10 et 12 mm épaisseurs.
- _Récommandé pour les environnements humides
- _Montage facile.
- _Pieds réglables en hauteur.
- _Vis et charnières en acier inoxydable.
- _Matériel très résistant, hydrofuge, ignifuge et antibactérien.
- _Nettoyage facile.



Opciones.

Options.
Choisir.

Bancos VESTUARIO

M003-15

- _Fabricado en acero esmaltado color gris.
- _Asiento en listones de pino barnizado.
- _Estructura soldada.
- _Gran resistencia.

WOODEN Benches

- _Manufactured in enamelled steel, colour grey.
- _Seat in varnished pine slats.
- _Welded structure.
- _Great resistance.

Bancs VESTIAIRES

- _Fabriquée en acier peint, couleur gris.
- _Assise en lattes de pin verni.
- _Structure soudée.
- _Grande résistance.



M003-mini



REF



KG

| | | |
|-----------|-----------------|-------|
| M003-mini | 700x325x480 mm | 8 kg |
| M003-10 | 1000x325x480 mm | 10 kg |
| M003-15 | 1500x325x480 mm | 14 kg |
| M003-20 | 2000x325x480 mm | 18 kg |

colectividades

colectivities
colectivités

bancos / benches / bancs
sillas / chairs / chaises
archivador / filing cabinets / classeur

Bancadas

MDB4P

- _Estructura metálica pintada, color negro.
- _Asiento y respaldo en polipropileno (-P), tapizado (-T) y en madera barnizada (-M).
- _3, 4 ó 5 asientos.

Benches

- _Metallic structure, black epoxy painted.
- _Polypropilene (-P), upholstered (-T) or wooden (-M) seat and backrest.
- _3, 4 or 5 seats.

Bancs

- _Fabriquée en acier peint noir.
- _Dossier et fond en polypropylène (-P), tapissés (-T) ou en bois (-M).
- _3, 4 ou 5 fond.



Silla de CONFIDENTE

- _Silla fija, 4 patas
- _Apilable.
- _Varios colores disponibles.
- _MD51201: Estructura metálica pintada. Asiento y respaldo tapizado.
- _MD51211: Estructura metálica cromada. Carcasa polipropileno.

STACKABLE Chair

- _Fixed chair, with 4 legs.
- _Stackable.
- _Several available colours.
- _MD51201: Enamelled frame. Upholstered seat and back-rest.
- _MD51211: Chromed frame. Polypropylene seat and back-rest.

Chaise à EPLIER

- _Avec 4 jambes.
- _Chaise à empiler.
- _Plusieurs couleurs.
- _MD51201: Structure en acier peint. Fond et dossier tapissés.
- _MD51211: Structure chromé. Coque en polypropylène.

MD51201

MD51211

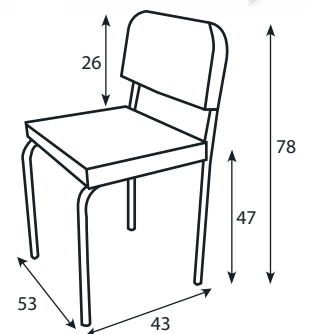

colectividades

colectivities
colectivités

bancos / benches / banques
sillas / chairs / chaises
archivadores / filing cabinets / classeurs

Sillón de DIRECCIÓN

- _Sillón de respaldo medio o alto.
- _Respaldo y asiento tapizados, disponible en varios colores.
- _Con reposabrazos.
- _Base con 5 ruedas.
- _Elevación a gas.

🇬🇧 Armchair

- _Medium or high back-rest.
- _Upholstered in several colours.
- _With arm-rest.
- _Base with 5 rolling wheels.
- _Height adjustment by gas spring.

🇫🇷 Fauteil

- _Dossier medium ou haute.
- _Fond et dossier tapissés (plusieurs couleurs).
- _Appui bras.
- _Base avec 5 roulettes.
- _Réglable en hauteur à gaz.

MD51202



MD51212

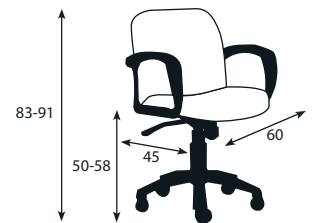
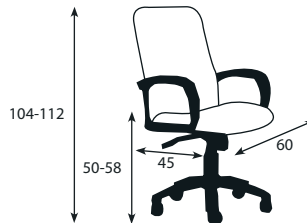

Archivadores

- _Fabricado en acero esmaltado epoxy.
- _Guía normal sobre cojinete.
- _Cerradura con llave.
- _Modelos con 3 o 4 cajones.
- _Opción: carpetas.

🇬🇧 Filing Cabinets

- _Enamelled steel construction.
- _Guide normal on bearing.
- _Lock with key.
- _3 or 4 drawers.
- _Option: folders.

🇫🇷 Classeurs

- _Acier peint epoxy.
- _Guide normal sur roulement.
- _Bloquer avec clé.
- _3 ou 4 tiroirs.
- _À choisir: chemises.

MD51006

MD51012



MD51012

470x650x1025 mm

MD51006

470x650x1327 mm

Armario PUERTAS CORREDERAS

- _Fabricado en acero esmaltado epoxy.
- _Puertas correderas de cristal (-C) o metálicas (-M).
- _Cerradura con llave.
- _Laterales interiores perforados para poder colocar estantes. (estantes no incluidos)
- _Consultar otras medidas disponibles.

Cabinets with SLIDING DOORS

- _Manufactured in enamelled steel.
- _Sliding doors, metallic (-M) or glass (C).
- _Lock with key.
- _Inner sides perforates to place shelves. (shelves not included).
- _Consult available measurements.

Armoires avec PORTES COULISSANTES

- _Fabriqué en acier epoxy (-C).
- _Portes coulissantes, en vitre ou métallique (-M)
- _Serrure avec clé.
- _Intérieurs latéraux perforés pour placer des étagères. (étagères non inclus).
- Consultez d'autres mesures disponibles.

MD510016-M



MD510016-C



| | |
|--------------|------------------|
| MD510016-C/M | 1000x450x1386 mm |
| MD510017-C/M | 1000x450x1806 mm |
| MD510018-C/M | 1000x450x1980 mm |

Armario PUERTAS PERSIANA

- _Fabricado en acero esmaltado epoxy.
- _Puertas de persiana.
- _Cerradura con llave.
- _Laterales interiores perforados para poder colocar estantes. (estantes no incluidos)
- _Consultar otras medidas disponibles.

ROLLER SHUTTER cabinet

- _Manufactured in enamelled steel.
- _Roller shutter door.
- _Lock with key.
- _Inner sides perforates to place shelves. (shelves not included).
- Consult available measurements.

Armoire À RIDEAU ROULANT

- _Fabriqué en acier epoxy.
- _Porte à rideau roulant.
- _Serrure avec clé.
- _Intérieurs latéraux perforés pour placer des étagères. (étagères non inclus).
- _Consultez d'autres mesures disponibles.



| | |
|------------|------------------|
| MD510016-P | 1200x450x1396 mm |
|------------|------------------|

colectividades

colectivities
colectivités

archivadores / filing cabinets / classeurs
armarios / cabinets / armoires
mesa despacho / desk / table bureau

Mesa de DESPACHO

MD51203

Tableros, patas y cajones en melamina.
Cantos revestidos en PVC.
Consultar colores y medidas disponibles.
Opción: cajonera con ruedas.
Disponible modelo con patas metálicas (-M).

🇬🇧 Desk

Top, legs and drawers in melamine.
Edges coated with PVC.
Consult available measures and colours.
Option: mobile drawers unit, on wheels.
Available: model with metallic legs (-M).

🇫🇷 Table

Plan de travail, jambes et tiroirs en mélamine.
Bords revêtus de PVC.
Consultez les mesures et les couleurs disponibles.
Option: tiroirs avec roulettes.
Disponible: modèle avec pieds métalliques (-M).



| | |
|---------|-----------------|
| MD51203 | 1400x800x740 mm |
| MD51213 | 1600x800x740 mm |
| MD51223 | 1800x800x740 mm |
| MD51233 | 2000x800x740 mm |





ayudas técnicas
y material médico

technical aids and
medical equipment

aides techniques et
équipement médical

Andador Rollator con y sin asiento



Andador rollator de aluminio. Con 2 ruedas delanteras interiores para un mejor manejo en espacios estrechos. Fácilmente plegable, puños regulables en altura.

Ref: M189-A con asiento
Ref: M189 sin asiento

Andador Rollator sin asiento



Andador rollator de aluminio. Con 2 ruedas delanteras, puños anatómicas regulables en altura. Estructura muy ligera y resistente. Disponible en varios colores:

Ref: M183

Andador Rollator con asiento y sin asiento



Andador rollator de aluminio. Con dos ruedas delanteras dobles, puños anatómicos regulables en altura. Estructura muy ligera y resistente. Disponible con y sin asiento y varios colores.

Ref: M183-A azul con asiento
Ref: M183-P pistacho con asiento
Ref: M183-B-A azul sin asiento
Ref: M183-B-C coral sin asiento

Andador con asiento Actio2



Andador rollator de aluminio. Con 2 ruedas delanteras, puños anatómicos regulables en altura. Con asiento acolchado, fácilmente plegable y ligero.

Ref: M189-PA

Andador Rollator con respaldo



Andador rollator de aluminio. Con 4 ruedas, asiento acolchado, respaldo y cesta. Fácilmente plegable y puños regulables en altura. Incluye frenos con función de bloqueo.

Ref: M189-D

Andador Rollator Banjo



Andador rollator de aluminio. Con 4 ruedas. Incluye cesta, bandeja, asiento y frenos con posibilidad de bloqueo. Fácilmente plegable y puños regulables en altura.

Ref: M189-B

Silla de ruedas M320. Rueda grande



Silla de ruedas de acero plegable. Reposabrazos y reposapiés abatibles y desmontables. Chasis muy manejable y robusto. Anchos de asiento disponibles:

Ref: M320-40 Asiento 40 cm
Ref: M320-43 Asiento 43 cm
Ref: M320-46 Asiento 46 cm

Silla de ruedas M330. Rueda pequeña



Silla de ruedas de acero plegable. Reposabrazos y reposapiés abatibles y desmontables. Chasis muy manejable y robusto. Anchos de asiento disponibles:

Ref: M330-40 Asiento 40 cm
Ref: M330-43 Asiento 43 cm
Ref: M330-46 Asiento 46 cm

movilidad

mobility
mobilité

sillas de ruedas / wheelchair / fauteuils roulants
grúa de traslado / crane transfer / transfert de pont roulant
tabla transfer / table transfer / table transfer
bastones / canes / canes

Silla de ruedas M310



Silla de ruedas robusta fabricada en acero. Reposapiés abatibles, reposabrazos acolchados, asiento y respaldo ergonómicos y frenos manuales.

Ref: M310 Asiento 46 cm

Silla de ruedas M308



Silla de ruedas de acero plegable. Reposabrazos abatibles, reposapiés abatibles y desmontables. Chasis muy manejable y robusto. Anchos de asiento disponibles:

Ref: M308-43 Asiento 43 cm
Ref: M308-46 Asiento 46 cm

Silla de ruedas Breezy M309



Silla de ruedas de acero plegable. Reposabrazos y reposapiés abatibles y desmontables. Silla versátil y de alta calidad. Anchos de asiento disponibles:

Ref: M309-42 Asiento 42cm
Ref: M309-45 Asiento 45cm

* También disponible con rueda trasera pequeña

Silla de ruedas Breezy M301 Rueda grande



Silla de ruedas de acero plegable. La más completa y versátil del mercado. Admite multitud de accesorios.

Ref: M301-37 Asiento 37cm
Ref: M301-40 Asiento 40cm
Ref: M301-43 Asiento 43cm
Ref: M301-46 Asiento 46cm
Ref: M301-49 Asiento 49cm
Ref: M301-52 Asiento 52cm

Silla de ruedas Breezy M301-P Rueda pequeña



Silla de ruedas de acero plegable. La más completa y versátil del mercado. Admite multitud de accesorios.

Ref: M301-P37 Asiento 37cm
Ref: M301-P40 Asiento 40cm
Ref: M301-P43 Asiento 43cm
Ref: M301-P46 Asiento 46cm
Ref: M301-P49 Asiento 49cm
Ref: M301-P52 Asiento 52cm

Grúa eléctrica de traslado con Arnés



Grúa de elevación y traslado de pacientes y enfermos. Diseño innovador y compacto. Potencia la seguridad y comodidad tanto del usuario como de su cuidador. 2 modelos disponibles:

Ref: MOEUL-B150 Soporta 150 kg
Ref: MOEUL-B180 Soporta 180 kg

Tabla transfer de pacientes



Tabla Transfer estándar plegable de pacientes para uso intensivo. Asas integradas en cada extremo de la tabla para mayor seguridad y revestimiento suave para la piel.

Ref: IN0011

Medida: 178x50 cm
Soporta: 150 kg

Bastón inglés regulable



Bastón inglés con diseño ergonómico, regulable en altura y fabricado en aluminio de alta calidad. Soporta hasta 130 kg de peso.

Ref: M185

baño e higiene

bath and hygiene

bains et hygiène

sillas de baño / chairs bath / chaise bains
elevadores / elevated toilet seat / rehausse wc
taburetes de baño / seats bath / seats bains

Silla de habitación con WC



Silla de habitación con wc. Chasis de acero y asiento acolchado con espuma. Se fija con un sistema de clips, el cubo se puede quitar por los lados o por arriba para su fácil limpieza.

Ref: MBA0036 Soporta 130 kg

Silla de habitación con WC



Silla de habitación con wc. Asiento y respaldo acolchado con espuma. Se accede al cubo por el lateral de la silla para su fácil limpieza. Altura asiento: 50 cm.

Ref: MBA0035

Silla de ducha con ruedas



Silla de ducha de aluminio para baño. Permite una higiene personal más segura y cómoda. Incluye reposapiés, reposabrazos, tirador y 4 ruedas, 2 de ellas con freno.

Ref: MBA0031 Soporta 100 kg

Elevador de WC 10 cm



Se fija fácilmente en la gran mayoría de WC. Permite un uso más seguro del inodoro, con una mínima flexión de rodillas. Ideal para personas con baja movilidad. Disponible con y sin tapa.

Ref: MB0027 Sin tapa
Ref: MB0017 Con tapa

Elevador de WC 11 cm



Se fija fácilmente en la gran mayoría de WC. Su innovador diseño le permite soportar hasta 185 kg de peso y una gran seguridad en su fijación gracias a los 4 clips de cierre. Disponible con y sin tapa.

Ref: MBA0037 Sin tapa
Ref: MBA0037-T Con tapa

Elevador blando de WC



Se fija fácilmente en la gran mayoría de WC. El núcleo de espuma inyectada permite que su tacto sea blando, ideal para un mayor confort en el baño. Fácil limpieza y desinfección. Su elevación es de 11 cm.

Ref: MBA0038 Sin tapa
Ref: MBA0038-T Con tapa

Taburete redondo para baño



Permite una higiene personal práctica y segura. Ligero gracias a su estructura de aluminio y regulable en altura. Con conteras antideslizantes para mayor estabilidad. Soporta hasta 100 kg de peso.

Ref: TAU3

Taburete acolchado de baño



Permite una higiene personal práctica y segura. Ligero gracias a su estructura de aluminio y regulable en altura. Con conteras antideslizantes para mayor estabilidad. Soporta hasta 100 kg de peso.

Ref: TAU2

baño e higiene

bath and hygiene
bains et hygiène

sillas de baño / seats bath / seats bains
taburetes de baño / stool bath / tabouret bains
cuñas y orinales / wedges and urinals / cales et urinoirs
esponjas de baño / bath sponges / éponges de bain

Silla de baño acolchada



Permite una higiene personal práctica y segura. Ligera gracias a su estructura de aluminio y regulable en altura. Con conteras antideslizantes para mayor estabilidad. Soporta hasta 100 kg de peso.

Ref: SA2

Silla de baño con respaldo



Silla de baño fabricada en pvc y aluminio. Patas con conteras antideslizantes y regulables en altura hasta 8 niveles. Asiento ergonómico con orificios que permiten el drenaje del agua.

Ref: SA1

Silla de baño en U con respaldo



Silla de baño fabricada en pvc y aluminio. Patas con conteras antideslizantes y regulables en altura hasta 8 niveles. Asiento ergonómico con orificios que permiten el drenaje del agua.

Ref: SAU1

Banqueta de baño sin respaldo



Banqueta de baño fabricada en pvc y aluminio. Patas con conteras antideslizantes y regulables en altura hasta 8 niveles. Asiento ergonómico con orificios que permiten el drenaje del agua.

Ref: TA1

Banqueta de baño en U sin respaldo



Banqueta de baño fabricada en pvc y aluminio. Patas con conteras antideslizantes y regulables en altura hasta 8 niveles. Asiento ergonómico con orificios que permiten el drenaje del agua.

Ref: TAU1

Cuña sin tapa



Fabricada en polipropileno, material muy resistente a lejías, detergentes y golpes. Esterilizable en autoclave, forma anatómica para un uso cómodo.

Ref: M496P

Orinal de caballero



Fabricado en polietileno. Forma anatómica para un uso cómodo. Graduado cada 100 cc. hasta un máximo de 1000 cc.

Ref: M496U

Esponjas jabonosas. Paquete 24 uds.



Esponja que permiten una perfecta higiene sin apenas agua ni enjuague. Son hidratantes y suavizantes. Su gel, indicado para pieles sensibles, se activa con sólo unas gotas de agua.

Ref: UM0116

antiescaras

antibedsosres

antiescarres

colchones / mattresses / matelas

cojines / cushions / coussins

Colchón antiescaras con compresor



Colchón que alivia la presión y previene la aparición de escaras en personas encamadas. Fabricación en pvc ignífugo, contiene 130 celdas independientes de aire.

Ref: Q114

Colchón antiescaras mod. superior



Colchón que alivia la presión y previene la aparición de escaras en personas encamadas. Fabricación en pvc ignífugo, contiene 17 celdas independientes de aire.

Ref: Q115

Cojín antiescaras cuadrado



Cojín adaptable a cualquier asiento o silla. Previene la aparición de úlceras por presión gracias a su relleno de fibra silicona y su funda exterior de algodón y poliéster. Dimensiones: 44x44x9 cm

Ref: MBA0039

Cojín antiescaras de anillo



Cojín adaptable a cualquier asiento o silla. Previene la aparición de úlceras por presión gracias a su relleno de fibra silicona y su funda exterior de algodón y poliéster. Dimensiones: 44x9 cm. Diámetro interno de 15 cm.

Ref: MBA0040

Cojín antiescaras de aire



Se adapta perfectamente a cualquier asiento y persona. Formado por multitud de celdas independientes de aire que distribuyen la presión. Incluye bomba de inflado y kit de reparación. Peso máx. 150 kg Dimensiones: 42x42 cm.

Ref: MBA0041

Cojín antiescaras flotación líquida



Adaptable a cualquier asiento o silla. Compuesto por una funda impermeable y transpirable, base de foam y relleno de gel líquido de silicona. Previene la aparición de úlceras por presión. Dimensiones: 40x40x6 cm.

Ref: MBA0042

Cojín antiescaras de gel líquido



Adaptable a cualquier asiento o silla. Compuesto por una funda de poliéster de rizo plastificado, extraíble y con cremallera. Relleno de un polímero de celulosa con glicoles. Previene la aparición de úlceras por presión. Dimensiones: 40x40x6 cm.

Ref: MBA0043

Cojín antiescaras viscoelástico



Adaptable a cualquier asiento o silla. Compuesto por una funda tipo M1 ignífuga, rellena de espuma viscoelástica expandida. Previene la aparición de úlceras por presión. Dimensiones: 40x40x6 cm.

Ref: MBA0044

Cabestrillo de inmovilización



Sistema de sujeción indicado para soportar el brazo lesionado mediante adaptación al cuello. Sistema de cierre de velcro y tejido transpirable.

Ref: MBA0045-S Talla S
Ref: MBA0045-M Talla M
Ref: MBA0045-L Talla L

Collarín cervical blando



Elemento necesario para inmovilizar la columna cervical en casos de traumatismos, luxaciones, hernias... Sistema de cierre con velcro. Fabricado en poliuretano y algodón hipoalérgico. Tallas disponibles:

Ref: MBA0046-S Talla S
Ref: MBA0046-M Talla M
Ref: MBA0046-L Talla L

Vendaje kinesiológico. 1 rollo



Pedir en múltiplos de 12 uds.

Da soporte y estabilidad a músculos y articulaciones sin afectar a amplitud de movimiento. Mejora articulación y drenaje linfático. Disponible en varios colores:

Ref: IN00004-AZ Azul
Ref: IN00004-BG Beige
Ref: IN00004-NG Negro
Ref: IN00004-RS Rosa

Collarín cervical semi-rfido



Elemento necesario para inmovilizar la columna cervical en casos de traumatismos, luxaciones, hernias... Sistema de cierre con velcro. Fabricado en poliuretano y algodón hipoalérgico. Tallas disponibles:

Ref: MBA0046SR-S Talla S
Ref: MBA0046SR-M Talla M
Ref: MBA0046SR-L Talla L
Ref: MBA0046SR-XL Talla XL
Ref: MBA0046SR-E Talla E

Compresor de goma plano. 100 uds.



Cinta de goma para aplicación de presión en la raíz de las extremidades, a fin de dificultar el retorno venoso, facilitando su acceso para para punción, extracción de sangre, colocación de catéteres. Libre de látex.

Ref: MBA0047

Otoscopio Ri-Mini Riester



Explora e ilumina el conducto auditivo con total garantía. Sistema de fibra óptica para iluminación óptima. Lámpara halógena de 2,5V y lupa desmontable de 2,5 aumentos. Incluye espéculo auricular de 4 mm.

Ref: IN00047

Oto/ofthalmoscopio Ri-Mini Riester



Explora e ilumina el conducto auditivo con total garantía. Sistema de fibra óptica para iluminación óptima. Lámpara halógena de 2,5V y lupa desmontable de 2,5 aumentos. Incluye espéculo auricular de 4 mm. Incluye oftalmoscopio.

Ref: M7016

Laringoscopio standard Macintosh



Conjunto laringoscopio Ri-standar Macintosh con palas nº 2, 3 y 4. Mango para pilas tipo C, no recargable.

Ref: IN004

Espéculo, 500 uds. Riester



Espéculo auricular para otoscopio ri-mini color negro. Marca alemana de máxima fiabilidad, Riester. Disponible para adulto y pediatría

Ref: IW00048-A Adulto
Ref: IW00048-P Pediátrico

Fonendoscopio de adulto



Fonendo con doble campana fabricando en acero inoxidable. Arco biauricular con resorte ensamblado al interior del tubo. Anillo con protección al frío. Color negro, campana de 23 mm.

Ref: M7009

Fonendoscopio duplex. Riester



Fonendo de alta calidad con contacto de doble precisión. Anillos con protección contra el frío. Gran calidad acústica, ligereza y fácil manejo. Longitud total 77 cm, campana de 36 mm.

Ref: M7012

Ri-Former 2 mangos 3.5V/230V



Consta de dos mangos y sin reloj digital, conectado a la red de electricidad, libre de baterías. Incluye placa mural, tacos, tornillos y esquema de montaje. No incluye cabezales. Marca Riester. También disponible en 1 sólo mango.

Ref: M7004-1 1 mango
Ref: M7004-2 2 mangos

Tensiómetro anaeroide. Riester



Marca Riester, máxima fiabilidad, fabricación alemana. Unión atornillada del tubo y mango de cuchara ergonómico de acero inoxidable.

Ref: Qo68 Minimus II
Ref: Qo68-3 Minimus III

Tensiómetro anaeroide 2 salidas



Medición monomanual de la tensión arterial. Con doble tubo, diseñado para otorgar máxima precisión y duración de vida útil.

Ref: M7011 Adulto
Ref: M7011-O Obeso

Pulsioxímetro digital compacto



Indica pulsaciones y porcentaje de saturación de oxígeno en sangre. Pequeño y fácil de usar, hasta 32 horas de autonomía con 2 pilas AAA incluidas con el artículo.

Ref: M7017

Tensiómetro digital de brazo



Gran precisión y comodidad en su uso. Almacena hasta 99 memorias, detecta pulso irregular, arritmias y tiene función de apagado automático. Incluye pilas y funda para ser transportado.

Ref: M7018

Tensiómetros digitales. Omron



Marca líder que garantiza gran exactitud y fiabilidad, validez clínica cumpliendo el protocolo internacional. Detecta pulso irregular y tiene memoria para multitud de mediciones. Incluyen estuche protector para ser transportados.

Ref: M7019-B Brazo
Ref: M7019-M Muñeca

Termómetro digital de punta flexible



Indica rápidamente la temperatura corporal en axilas, boca y recto. Incluye pilas 192 o LR41 (1,55V) intercambiables. Rango de medida de 32 a 42 °C. Apagado automático tras 16 min. de inactividad. Pantalla de cristal con 3 dígitos.

Ref: IN00017

Desfibrilador semiautomático



Modelo Samaritan PAD 350 P. Preparado para poder ser utilizado por personas no especialistas en cualquier circunstancia. Válido para adultos y niños.

Ref: M7020

Vaso unidosis y tapas



Vasitos para suministrar medicación oral en el sistema unidosis. Material plástico transparente. No estéril. Capacidad 30 ml, graduado. También disponible tapadera para el vaso.

Ref: MBA001-3 Vasito 3750 uds.
Ref: MBA001-4 Tapadera 4000 uds.

Colgador para bolsa de orina



Soporte metálico cromado en color zinc, adaptable a la barra de la cama y sobre el cual se cuelga una bolsa de orina de 2 litros de capacidad. Pedir en múltiplos de 10 unidades.

Ref: M7023

Electrocardiógrafo AR 600 ADV



Capaz de capturar y digitalizar simultáneamente las 12 derivaciones ECG e imprimirlas con la impresora térmica integrada. Doble sistema de alimentación, red y acumulador interno.

Ref: M7021

Gel conductor ultrasonidos 5l. 4 uds.



Gel para diagnóstico y terapia con ultrasonidos. Sin sal. No irrita la piel. No engrasa. Hidrosoluble. No daña el transductor. Se extiende fácil y uniformemente.

Ref: M7022

Precinto de seguridad. 1000 uds.



Precinto para asegurar el cierre de contenedores. Fabricado en polipropileno. Precinto no enumerado color azul.

Ref: ME00015-03

ÍNDICE ALFABÉTICO

| REF | DESCRIPCIÓN | PAG | REF | DESCRIPCIÓN | PAG |
|------------|--|---------|------------|---|---------|
| M183 | Andadores. | 165 | MCE350 | Cesta para colgar de acero inoxidable AISI 304. | 35 |
| MD51012 | Archivadores metalicos de cajones. | 161 | MCE45050 | Cesta para estantería acero inoxidable. | 144 |
| MLA804-1 | Armarios de acero inoxidable. | 151-153 | MB180C | Cesta porta sondas. | 37 |
| MD510016-C | Armarios metalicos. | 162 | C100 | Cestas de medicación ISO. | 28 |
| MDB3M | Bancada de 3 plazas, 4 plazas, 5 plazas. | 160 | MCE514 | Cestas esterilización acero inoxidable. | 120 |
| M003-10 | Bancos de vestuario. | 159 | MCE525 | Cestas usos múltiples acero inoxidable. | 119 |
| C015 | Bandeja ISO 6040 para SERIE 2000. | 140 | MBA0039 | Cojín antiescaras. | 169 |
| OP888-26-L | Bandeja lateral extraíble con cerradura para PC. | 36 | Q114 | Colchón antiescaras con compresor. | 169 |
| OP888-35 | Bandeja acero inoxidable para soporte. | 35 | M034-HC | Colchón cuna corralito. | 55 |
| M885 | Bandeja auxiliar abatible acero inoxidable. | 36 | MED007-A | Colchón espuma de 5 mm tapizado blanco. | 14 |
| MB2000-7 | Bandeja de medicación. | 28 | M7023 | Colgador para bolsa de orina. | 172 |
| MED0035 | Bandeja lateral acero inoxidable AISI 304. | 16 | MBA0046-S | Collarín cervical. | 170 |
| OP888-7 | Bandeja lateral fija. | 36 | MBA0047 | Compresor de goma plano. 100 uds. | 170 |
| MB4000-E | Bandeja semanal. | 33/140 | Mo85-A | Cubos quirófano acero inox. Base rodable acero inox. | 122 |
| OP888-26 | Bandeja superior extraíble fenólico. | 36 | Mo34-CO | Cuna corralito acero inoxidable. | 55 |
| MED0011-A | Bandeja suspendida de acero inox. AISI 304. | 14 | Mo34-A | Cuna presalida,acero inoxidable. | 55 |
| NOR | Bandejas Gastronorm, acero inoxidable. | 121 | M496P | Cuña sin tapa y orinal caballero. | 168 |
| Mo12 | Banquillos 1-2-3 peldaños. | 107 | M7020 | Desfibrilador semiautomático. | 172 |
| OP888-10 | Barandilla tres lados por plano. | 35 | FM00110 | Dispensador cepillos, gorro, zapatillas,cofia acero inox. | 154 |
| E290 | Barra y soporte de seguridad. | 119 | M891 | Dispensadores transparentes basculantes. | 35 |
| M211-CE | Básculas. | 118 | MED0036-A | Doble soporte desfibrilador. | 15 |
| M185 | Bastón inglés regulable. | 166 | M889-P | Dosificador de jabón. | 37 |
| Mo23 | Biombos. | 112 | M7021 | Electrocardiógrafo AR 600 ADV. | 172 |
| OP888-34 | Bloqueador de cajones mediante precintos. | 34 | MBA0038 | Elevador blando de WC. | 167 |
| MBA0045-L | Cabestrillo de inmovilización, TALLA M-P-G. | 170 | IW00048-A | Espéculo, 500 uds. | 171 |
| M605 | Cabinas en compacto fenólico. | 159 | UM0116 | Esponjas jabonosas. Paquete 24 uds. | 168 |
| M3012 | Cajetin azul 300x120x100h. | 32 | MLA-1 | Estanterías modulares 5 baldas. | 143 |
| CS183 | Cajetin de medicación unidosis. | 28 | MED0044 | Foco halógeno 35W baja temperatura. | 14 |
| MED0013 | Cajón basculante lateral transparente. | 16 | M7009 | Fonendoscopios. | 171 |
| MD51205 | Cajonera con ruedas. | 163 | Mo105PFG | Fregaderos industriales. | 146 |
| M7818-HR | Cambiador de pared HORIZONTAL-VERTICAL. | 57-58 | M7022 | Gel conductor ultrasonidos 5l. 4 uds. | 172 |
| M163PL | Camilla plegable a pared, esmaltada. | 77 | M484 | Grifos. | 137/148 |
| M170 | Camillas de obesos. | 80 | MOEUL-B150 | Grúa eléctrica de traslado con Arnés. | 166 |
| M479 | Caño monomando clínico 1 agua, de pared. | 148 | M194-A | Lámparas de exploración. | 109-111 |
| MD51020 | Carpeta rayos (cajas de 50 unidades). | 48 | IN004 | Laringoscopio standard Macintosh. | 170 |
| M2000-E-F | Carro de endoscopia. | 50 | M470 | Lavabos. | 148-149 |
| Mo41 | Carro transporte cadáveres acero inoxidable. | 50 | M496 | Lavacañas. | 152 |
| M8001 | Carros abiertos para cestas ISO 6040. | 53 | Jq760 | Medtrolley Carros Hospitalarios. | 9-16 |
| Mo53 | Carros de Curas. | 39-40 | Mo86 | Mesa anestesia. | 64 |
| Mo75-B2 | Carros de distribución. | 42-44 | M181-M2 | Mesa de cama o atril elevación manual. | 71-72 |
| Mo71-1 | Carros de escayola, acero inoxidable. | 41 | MD51203 | Mesa de despacho. | 163 |
| M4020 | Carros de medicación. | 33 | M199 | Mesa de disección, acero inoxidable. | 70 |
| M3000 | Carros de Medicación Unidosis. | 32 | M106-R | Mesa instrumental campo, 4 ruedas acero inox. | 68 |
| Mo42X | Carros de Transporte paciente. | 51-52 | M110 | Mesa instrumental curva o de riñón. | 66 |
| M1000 | Carros hospitalario SERIE 1000. | 22 | M113 | Mesa instrumental en L, 1900, acero inoxidable. | 71 |
| M2000 | Carros hospitalario SERIE 2000 ISO 6040. | 29 | M105 | Mesa instrumental Mayo. | 67 |
| M800 | Carros hospitalario SERIE 800. | 17 | M100 | Mesa instrumental mixta, acero inoxidable. | 64 |
| M900 | Carros hospitalario SERIE 900. | 17 | M101 | Mesa instrumental recta. | 65 |
| M2000M | Carros hospitalarios SERIE 2000 MINI. | 23 | Mo81-l | Mesa para pesa bebés acero inox. | 56 |
| MB185-4 | Carros modulares , acero inoxidable. | 145 | M167 | Mesas reconocimiento. | 74-81 |
| MLA102 | Carros para cestas y gran carga. | 41 | M161 | Mesa reconocimiento pediátrica. | 58 |
| Mo35 | Carros portabaldas. | 116 | Mo89 | Mesa toma de muestras, encimera tapizada. | 69 |
| M245-IE | Carros portahistorias. | 48-49 | Mo105C | Mesa Trabajo inoxidable. | 146 |
| Mo61 | Carros ropa limpia, mixto. Sucia. | 44-48 | M5001 | Mesa Veterinaria acero inoxidable. | 70 |
| OP888-9 | Cerradura para cajón. | 37 | Mo98-2B | Mesas auxiliares. | 60-63 |
| C100-45 | Cesta ABS 450x400x100mm. | 25 | Mo78-l-C2 | Mesas desnuda bebe. | 57 |
| Co50-45 | Cesta ABS 450x400x50mm. | 25 | Mo82 | Mesas extracción sangre. | 69 |

ÍNDICE ALFABÉTICO

| REF | DESCRIPCIÓN | PAG | REF | DESCRIPCIÓN | PAG |
|-------------|---|---------|------------------|---|---------|
| M153 | Mesas ginecológicas. | 78-79 | M3012S | Separador cajetin 120mm. | 32 |
| OP888-40 | Módulo lateral con 3 huecos. | 36 | MED0022 | Separador de cajones PVC extraible. | 36 |
| MLA701/2 | Mueble cerrado acero inoxidable. | 147 | CS183-S | Separadores para cajetin de medicacion 183x300x81. | 28 |
| M560 | Mueble lavabo paritorio acero inoxidable. | 150 | CS091-S | Separadores para cajetin de medicacion 91x300x81. | 28 |
| M358 | Muebles fijo ISO6040 modulares altos. | 139 | MED0024 | separadores para cajón tipo peine alto 70mm. | 36 |
| M330 | Muebles fijo ISO6040 modulares bajos. | 134-138 | OP888-100-400-TL | Separadores para Cestas 450 serie 2000 mini. | 25 |
| M221-A | Negatoscopios. | 108 | OP888-100-400 | Separadores para cestas ISO 6040. | 28 |
| MoSILL-4R | Opción 4 ruedas apra Mosill. | 87 | MD51211 | Silla confidente polipropileno. | 160 |
| Mo34-B | Opción bandeja inferior acero inoxidable. | 55 | MD51201 | Silla de confidente tapizada. | 160 |
| Mo42-3 | Opción bandeja porta objetos acero inoxidable. | 51 | MBA0036 | Silla de habitación con WC. | 167 |
| Mo42-6 | Opción banquillo un tramo en lateral para Mo42. | 51 | M301-37 | Silla de Ruedas. | 165-166 |
| Mo42-4 | Opción cesta portaobjetos acero inoxidable. | 51 | M272-R | Sillón clínico, acompañante, paciente. | 87-90 |
| Mo34-H | Opción colchón cuna presalida. | 55 | MD51202 | Sillón dirección. | 161 |
| M560-CO | Opción Colchonet. | 150 | M158-P | Sillón eléctrico de pología. | 85 |
| Mo42-1 | Opción portabombonas acero inoxidable. | 51 | M117 | Sillón extracción de sangre, acero inoxidable. | 83 |
| OPREPGAS | Opción Reposapiés taburete a gas CROMADO. | 100 | M117-EA | Sillón hemodialisis y/o quimioterapia. | 86 |
| OPREPGASN | Opción Reposapiés para taburete a gas NYLON. | 100 | M260 | Sillón levanta personas. | 93 |
| OP50ANTI | Opción rueda antiestática para taburete a gas. | 100 | M117-M | Sillón multifunción con apoya brazos para extracción. | 84 |
| OPT | Opción Tapizado ignifugo para taburetes. | 100 | M261 | Sillón reclinable, brazo desmontable. | 94 |
| Mo19-l | Opción tela infantil (por cuerpo). | 112 | M268 | Sillones estructura de madera geriatrico. | 90-93 |
| M240 | Optotipos. | 117 | M262 | Sofá cama 1 plaza. | 94 |
| MT904 | Orificio facial. | 81 | MJS001-B | Soporte botella, a pared, acero inoxidable. | 154 |
| M7016 | Oto/oftalmoscopio Ri-Mini Riester. | 170 | MED001-2-A | Soporte charnela en varilla. | 16 |
| IN00047 | Otoscopio Ri-Mini Riester. | 170 | MED001-2A | Soporte charnela en varilla. | 37 |
| OP888-11-25 | Papelera blanca de polipropileno , tapa basculante. | 122 | OP888-63 | Soporte coldoscopio. | 78 |
| OP888-0 | Papelera lateral acero inoxidable | 37 | MJS001 | Soporte cuña, a pared, acero inoxidable. | 154 |
| OP888-11 | Papelera lateral blanca | 37 | FM00025 | Soporte cuña, palangana y botella, a pared. | 154 |
| Mo76-C | Papelera tapa con pedal inoxidable | 121 | MED0016-01 | Soporte de perfil de aluminio con cajitas basculantes . | 14 |
| MPA45050-D | Parrillas para estantería acero inoxidable | 144 | OP002 | Soporte de suero con 4 ganchos ABS. | 16 |
| M214-B | Pesabebés | 56 | MED0021 | Soporte desfibrilador resina fenólica 8mm. | 15 |
| MBA45050 | Planos para estantería acero inoxidable | 144 | OP888-4 | Soporte desfibrilador resina fenólica 8mm. | 34 |
| M500 | Podoscopio cromado | 117 | MED800-4 | Soporte gotero en perfil de aluminio. | 115 |
| OP888-29 | Porta etiquetas para cajón. | 36 | MJS001-P | Soporte palangana, a pared, acero inoxidable. | 154 |
| OP888-1 | Portabombona para carro hospitalario. | 34 | FM00132 | Soporte para bolsas. | 37 |
| M188 | Portapalanganas. | 115-116 | OP888-41 | Soporte para botes punzantes regulable. | 37 |
| M499 | Portarrollos. | 81 | MED005-A | Soporte para caja guantes de 100 Ud, en acero inox. | 34 |
| M499-E | Portarrollos para camilla eléctricas. | 76 | OP888-5 | Soporte para cajitas basculantes. | 35 |
| Mo29-A-GC-4 | Portasueros. | 112-114 | MED001-A | Soporte para charnela en Pletina de acero inox. | 16 |
| OP888-3 | Portasueros carro hospitalario, 2 ganchos. | 34 | M191-M | Soporte para codo adaptado a mesa. | 115 |
| OP888-3-4 | Portasueros para carro hospitalario, 4 ganchos. | 34 | OP888-38 | Soporte para monitor. | 36 |
| MED0017 | Porta-sueros regulable en altura 2 ganchos. | 15 | MED800 | Soporte TFT en perfil de aluminio, con tabla fenólica. | 115 |
| MED0017-1 | Porta-sueros regulable en altura 4 ganchos. | 15 | M190 | Soportes de brazos y piernas. | 115 |
| ME100D | Poste para estanteria acero inox. | 144 | Mo29-MC3 | Soportes rodables con cestas para aparatos. | 114 |
| MED0015-03N | Precinto para cierre bloqueador de cajones. | 16 | OP888-2 | Tabla de Parada DE COMPACTO FENÓLICO 8MM. | 34 |
| MED0015-02 | Precinto para cierre bloqueador de cajones. | 16 | IN0011 | Tabla transfer de pacientes. | 166 |
| M555 | Puesto enfermería acero inox. | 150 | M20011L | Taburetes. | 95-100 |
| M7017 | Pulsioxímetro digital compacto. | 171 | TAU2 | Taburetes y banquetas para baño. | 167-168 |
| FM00086 | Rack movil y murales. | 120 | M219ST | Tallímetro adulto. | 118 |
| MED0018 | Rail Soporte aparatos para perfil de aluminio. | 14 | M218 | Tallímetro pediátrico. | 56 |
| OP888-36 | Rail Superior para soporte aparatos. | 35 | OP888-50 | Tapón facial. | 76 |
| OP888-30 | Reborde superior para encimera acero inoxidable. | 37 | M605-1l-250 | Taquillas metalicas. | 158 |
| OP888-27 | Riel con ganchos portasondas. | 35 | M7011 | Tensiómetros. | 171 |
| OP888-28 | Riel lateral aparatos. | 35 | M605-OP-EM | Terminal embellecedor de taquilla. | 158 |
| M7004-1 | Ri-Former. | 171 | IN00017 | Termómetro digital de punta flexible. | 172 |
| M499-R | Rollo de papel de celulosa para camillas. | 81 | MBA001-3 | Vaso unidosis 3750 unidades. | 172 |
| MED0010-A | Rompeampollas de acero inoxdable. | 34 | IN00004-AZ | Vendaje kinesiológico.colores. | 170 |
| M499-R | Ruedas con freno individual 125Ø. | 85 | M491 | Ventana Guillotina, acero inoxidable. | 152 |
| MR125CF | Ruedas para camilla Ø125mm. | 81 | M6004 | Vitrinas. | 102-105 |
| MR100CF | Ruedas para estantería de acero inoxdable. | 145 | | | |

Certificado del Sistema de Gestión de la Calidad



ER-1884/2003 - 002/00

AENOR, Asociación Española de Normalización y Certificación, certifica que la organización

MOBICLINIC, S.L.

dispone de un sistema de gestión de la calidad conforme con la norma ISO 9001:2008, amparado por el Certificado ER-1884/2003 cuyo titular es JOSÉ QUERALTÓ ROSAL, S.A.

para las actividades: El diseño y la producción de mobiliario metálico para uso clínico.

que se realizan en: PI EL PINO, CL PINO ALBAR, 24. 41016 - SEVILLA

Fecha de primera emisión: 2015-11-27
Fecha de expiración: 2018-09-14

AENOR Asociación Española de Normalización y Certificación
Avelino BRITO MARQUINA
Director General de AENOR

AENOR Asociación Española de Normalización y Certificación

Géova, 6. 28004 Madrid, España
Tel. 902 102 201 - www.aenor.es



THE INTERNATIONAL CERTIFICATION NETWORK

CERTIFICATE

IQNet and
AENOR
hereby certify that the organization

MOBICLINIC, S.L.

PI EL PINO, CL PINO ALBAR, 24.
41016 - SEVILLA

for the following field of activities

The design and the production of metallic furniture for clinical use.

has a

Quality Management System

Linked to the certificate

ES-1884/2003

Issued to

JOSÉ QUERALTÓ ROSAL, S.A.

which fulfills the requirements of the following standard

ISO 9001:2008

First issued on: 2015-11-27

Validity date: 2018-09-14

Registration Number: **ES-1884/2003-002/00**



AENOR Asociación Española de Normalización y Certificación
Michael Drechsel
President of IQNet

AENOR Asociación Española de Normalización y Certificación
Avelino BRITO
Chief Executive Officer

IQNet Partners:
AENOR Spain, AFNOR Certification France, AIB-Vincotte International Belgium, ANCE Mexico, APCER Portugal, CCC Cyprus, CISQ Italy, CQC China, CQM China, CQS Czech Republic, Cro Cert Croatia, DQS Holding GmbH Germany, FCAV Brazil, FONDONGIMA Venezuela, ICOTEC Colombia, IMC Mexico, Inspecta Certification Finland, IRAM Argentina, JQA Japan, KFQ Korea, MIRTEC Greece, MSZT Hungary, Nemko AS Norway, NSAI Ireland, PCB, Poland, Quality Austria, Austria, RIR Russia, SII Israel, SIQ Slovenia, SIRM QAS International Malaysia, SQS Switzerland, SRAC Romania, TEST St. Petersburg, Russia, TSE Turkey, YUQS Serbia.
IQNet is represented in the USA by: AFNOR Certification, CISQ, DQS Holding GmbH and NSAI Inc.
The list of IQNet partners is valid at the time of issue of this certificate. Updated information is available under www.iqnet-certification.com

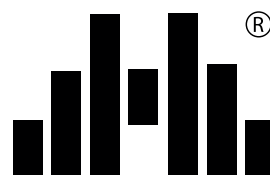

MOBICLINIC

Más de 25 años de innovación seguridad y
diseño fabricando mobiliario clínico.

Over 25 years of innovation and design security
hospital furniture manufacturing.

Plus de 25 ans d'innovation et de la sécurité de la conception
fabrication de meubles d'hôpital.



MOBICLINIC



Fabricantes de Mobiliario Clínico
Equipamiento de hospitales y laboratorios



Manufacturers Of Clinical Furniture
Equipment For Hospital and Laboratories



Fabricant de Mobilier Clinique
Equipement Hospitalier et Laboratoires



MOBICLINIC, S.L.

Pol. Ind. Fridex 38-39 , C.P. 41500
Alcalá de Guadaira (Sevilla) ESPAÑA
Tfno: (+34) 955 63 12 30
Fax: (+34) 955 63 10 79
Email: info@mobiclinic.com

www.mobiclinic.com
www.medtrolley.com



ISO 9001